



For Improved
Steam Quality

Series WDS Steam Separators

Applications

Watson McDaniel steam separators will remove a high degree, if not all, of entrained water in the steam space. Modern separators designed for steam service most effectively use the cyclonic style using the velocity of the steam to generate centrifugal force that whirls the steam and throws the entrained water to the wall of the unit where it drains to a steam trap installed under the unit. Separators must be properly sized to optimize the entrained water removal to assure the highest possible dryness. Sizing of separators for steam service is critical.

How They Work

Watson McDaniel steam separators condition steam to its highest possible dryness. This is critical for applications such as turbines, where the possibility of entrained water droplets in the steam will cause considerable damage. Also, a separator in the steam system will protect valves and other equipment from the ravages of entrained water. Steam conditioned through a separator will also provide better heat transfer.

Features

- High Efficiency
- Centrifugal Action
- Maximum Separation
- No Reentrainment
- Minimum Pressure Drop
- Code Constructed

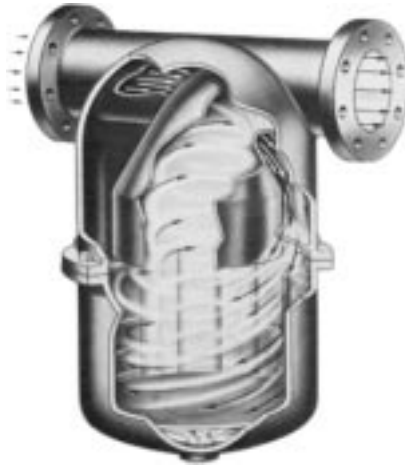

Type "T" Cast Iron

This separator is code constructed of cast iron and is suitable for a wide range of applications in steam lines. It is available with threaded ends in 3/4 to 3 inch pipe sizes and flanged ends in 2 to 5 inch sizes (125 lb. ANSI).

Cast Iron Separators
FNPT: 3/4", 1", 1 1/4", 1 1/2", 2", 2 1/2", 3"
125# Flanged: 2", 2 1/2", 3", 4", 5"



Type "T" Carbon Steel

ASME Code constructed of carbon steel for steam lines. Pipe sizes range from 1 inch to 12 inches. Ideal for installation in steam lines ahead of turbines or pressure reducing valves when high purity steam is desired.

Carbon Steel Separators
Cast Carbon Steel FNPT & Socketweld: 1", 1 1/4", 1 1/2", 2"
Fabricated Carbon Steel 150# & 300# Flanged: 1", 1 1/4", 1 1/2", 2", 2 1/2", 3", 4", 5", 6", 8", 10", 12"

Watson McDaniel reserves the right to change the designs and/or materials of its products without notice



WATSON McDANIEL COMPANY

975 Madison Ave. Valley Forge Corporate Center Norristown, PA 19403
www.watsonmcdaniel.com 610 666-5711 Fax 610 666-0404

Manufacturers of:

PRESSURE & TEMPERATURE REGULATORS - RELIEF VALVES - STEAM TRAPS - CLEAN STEAM PRODUCTS
LIQUID DRAINERS - PRESSURE PUMPS - EJECTORS - SPECIALTY PRODUCTS



SP-580

1/01

SPECIALTY
PRODUCTS

Separator Sizing Table

Capacities in lbs/hr of steam

Size NPS	Operating Pressure (psig)											
	5	10	25	50	100	150	200	250	300	400	450	500
1"	192	219	289	384	536	661	772	872	964	1132	1210	1284
1¼"	305	348	459	609	851	1050	1225	1384	1531	1797	1921	2038
1½"	434	495	653	868	1211	1495	1744	1970	2179	2559	2734	2902
2"	769	877	1156	1536	2143	2646	3087	3487	3857	4529	4839	5136
2½"	1220	1391	1834	2437	3401	4199	4900	5535	6121	7188	7680	8151
3"	1912	2181	2876	3821	5333	6583	7682	8677	9597	11269	12041	12779
4"	3183	3632	4787	6362	8878	10959	12788	14446	15977	18760	20046	21274
5"	4823	5501	7252	9637	13449	16603	19373	21884	24203	28420	30367	32229
6"	7465	8516	11226	14917	20818	25699	29988	33874	37464	43992	47006	49887
8"	12444	14196	18713	24867	34704	42840	49989	56468	62452	73334	78359	83161
10"	19376	22104	29137	38720	54036	66705	77836	87924	97241	114186	122009	129487
12"	28560	32580	42947	57071	79648	98320	114728	129597	143331	168306	179836	190859

Separator Sizing Table

Capacities in kg/hr of steam

Size NPS	Operating Pressure (barg)											
	0.5	1.0	2.0	5.0	8.0	10	12	15	20	25	30	34.5
1"	93	110	139	207	262	295	325	366	429	486	538	583
1¼"	147	174	220	329	416	468	516	582	681	772	855	925
1½"	210	248	313	468	593	666	734	828	970	1098	1217	1317
2"	371	438	554	829	1049	1179	1299	1466	1717	1944	2154	2330
2½"	589	696	880	1315	1665	1871	2061	2326	2725	3085	3418	3698
3"	924	1091	1379	2062	2610	2933	3232	3647	4272	4837	5358	5798
4"	1538	1816	2296	3433	4345	4883	5381	6071	7112	8053	8920	9652
5"	2329	2751	3478	5201	6582	7397	8151	9197	10774	12199	13514	14623
6"	3606	4258	5384	8050	10189	11449	12617	14237	16676	18883	20918	22634
8"	6011	7097	8975	13419	16984	19086	21033	23733	27800	31478	34870	37731
10"	9359	11051	13975	20895	26446	29718	32749	36953	43286	49013	54294	58750
12"	13795	16289	20599	30798	38980	43803	48271	54467	63802	72243	80028	86595

WDS Type "T" Steam Separator (Carbon Steel)

Dimensions (in inches) and Weights

Pipe Size	Thr'd. & Sock. Weld A	150# & 300# Flanged A	B	Cast C	Fab'd. C	D	Gauge Taps G	NPT Drain		Thr'd. & Sock Weld	150# Flg's.	300# Flg's.
								Std.	Opt'l.	Design 1000 PSIG @650°F	Design 150 PSIG @450°F	Design 500 PSIG @650°F
										Wgt.	Wgt.	Wgt.
1	6 $\frac{3}{8}$	10 $\frac{1}{2}$	10 $\frac{1}{2}$	12	16	5 $\frac{5}{16}$	O P T	1	1 $\frac{1}{2}$	29	33	35
1 $\frac{1}{4}$	6 $\frac{3}{8}$	10 $\frac{1}{2}$	10 $\frac{1}{2}$	12	16	5 $\frac{5}{16}$		1	1 $\frac{1}{2}$	30	35	37
1 $\frac{1}{2}$	7 $\frac{7}{8}$	11 $\frac{1}{2}$	12 $\frac{1}{2}$	14	19	6 $\frac{3}{8}$		1	2	55	50	56
2	7 $\frac{7}{8}$	11 $\frac{1}{2}$	12 $\frac{1}{2}$	14	19	6 $\frac{3}{8}$		1	2	57	55	59
2 $\frac{1}{2}$	—	16	15	—	22	8 $\frac{1}{8}$	5 $\frac{3}{4}$	1	2	—	100	110
3	—	18	18	—	26	10 $\frac{3}{4}$	5 $\frac{3}{4}$	1 $\frac{1}{2}$	2 $\frac{1}{2}$	—	140	150
4	—	20	22	—	31	12 $\frac{3}{4}$	5 $\frac{3}{4}$	1 $\frac{1}{2}$	2 $\frac{1}{2}$	—	195	220
5	—	22	26	—	36	14	7 $\frac{7}{8}$	1 $\frac{1}{2}$	2 $\frac{1}{2}$	—	230	290
6	—	24	30	—	41	16	7 $\frac{7}{8}$	1 $\frac{1}{2}$	2 $\frac{1}{2}$	—	350	380
8	—	28	37	—	50	18	7 $\frac{7}{8}$	2	3	—	475	610
10	—	34	55	—	70	24	7 $\frac{7}{8}$	2	3	—	780	1180
12	—	38	58	—	75	28	7 $\frac{7}{8}$	2 $\frac{1}{2}$	4*	—	940	1510

*Flanged Drain

Performance

The Watson McDaniel Type "T" entrainment separator, when properly sized, installed and drained, will remove 99% of all liquid droplets and solid particle entrainment where the droplet and/or particle size equals or exceeds ten microns.

Moisture-laden steam enters the inlet of the separator where it is deflected in a centrifugal downward motion. The entrained moisture is separated out by reduction in velocity. Separated liquid then falls below the Vortex Containment Plate where it cannot be reentrained. Dry, clean gas then flows upward and exits through the outlet of the separator.

These Type "T" separators are of steel construction in accordance with Section VIII, Division I of the ASME Code for unfired pressure vessels. Inlet and outlet connections can be rotated radially upon request.

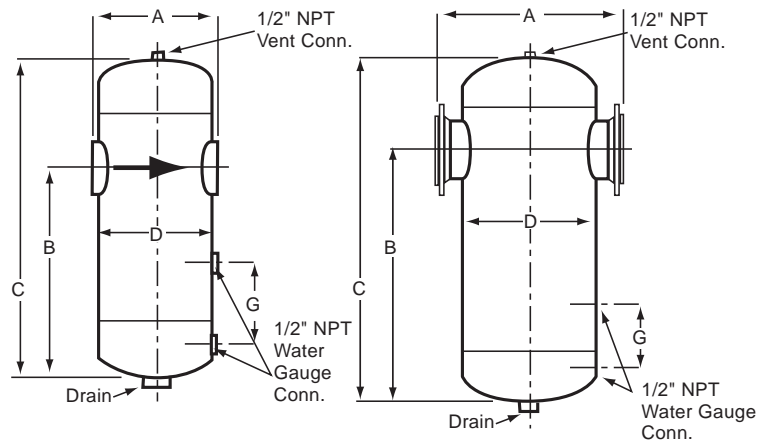

WDS Type "T" Steam Separator (Cast Iron)

Dimensions (in inches) and Weights



Pipe Size	Threaded A	125# Flanged A	B	Water Gauge C	D	NPT Drain		Threaded Net Weight Pounds	125# Flanged Net Weight Pounds
						Std.	Opt.		
3/4	5 1/2	—	9 1/4	—	4 1/2	3/4	—	14	—
1	6	—	9 1/4	—	4 3/4	1	—	16	—
1 1/4	6	—	9 1/4	Opt.	5 1/4	1	1 1/4	19	—
1 1/2	7 1/4	—	11 1/4	Opt.	5 1/2	1	1 1/2	29	—
2	8 1/2	10 1/4	13	Opt.	6 1/2	1	2	40	47
2 1/2	9 3/8	11 1/2	14 1/2	4 3/4	7 1/4	1	2	57	70
3	11 1/8	14 1/4	16 1/4	4 3/4	9	1 1/4	2 1/2	90	98
4	—	15 3/8	19 1/2	5 3/4	11 1/4	1 1/4	2 1/2	—	138
5	—	18 3/8	24 1/4	7 1/2	13 3/8	1 1/2	2 1/2	—	305

Applications

Watson McDaniel separators are designed for the removal of entrained liquid or solids from steam. This particular type is effective in applications where the system has an entrained liquid flow rate of up to 40% by weight of the unit's flow capacity.

Design

The Watson McDaniel Type "T" steam separator is designed to remove 99% of all liquids and solids, 10 micron size and larger, from the steam flow. The removal is accomplished by a design which causes the steam to enter a controlled centrifugal flow. This action forces the entrained liquids and solids to the outer wall. The Vortex Containment Plate guarantees no reentrainment, assuring a dry steam flow at the separator outlet.

ASME Code Construction

Standard Watson McDaniel Type "T" separators are furnished in cast iron conforming to ASTM A-278. The separators are designed and constructed to ASME code for unfired vessels, Section VIII, Division I. An ASME stamp is available on sizes 2" and over.

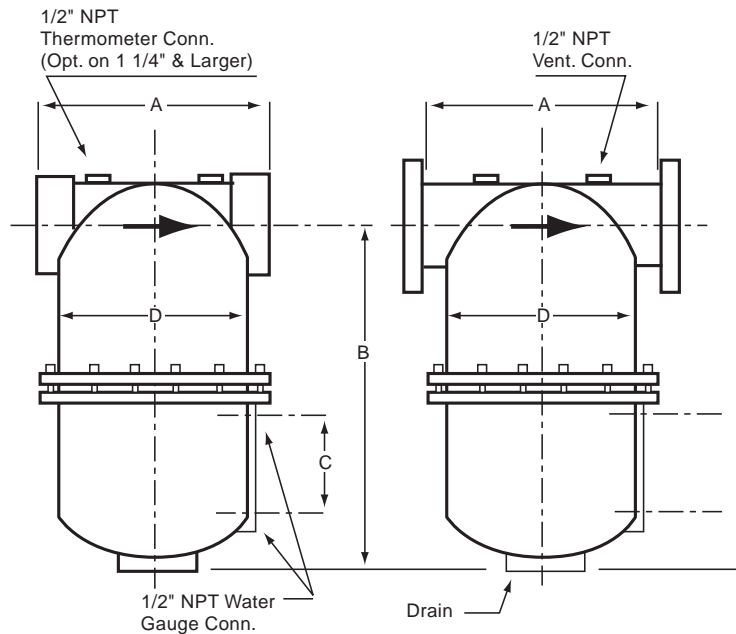

Pressure and Temperature Ratings

Threaded NPT	125 lb. ANSI Flanges
160 PSIG at 450°F	150 PSIG @ 450°F
250 PSIG at 250°F	
320 PSIG (Hydrostatic)	320 PSIG (Hydrostatic)