

# SERIES PMPC, PMPF, PMPSS, PMPLS, PMPM, PMPBP, & PMPSP INSTALLATION & MAINTENANCE

INSTRUCTION PART NO.1501226

REVISION 2

## APPLICATIONS

The Pressure Motive Pump is recommended when liquids must be moved to a higher elevation, higher pressure, or greater distances. Typical applications are:

- Condensate from Vacuum or Low Pressure Systems.
- Condensate Systems with High Back Pressure.
- Any Steam Condensing Equipment (i.e., some underground steam distribution systems, tank farms, etc.)
- Remote Installation (i.e. Tank Farms)
- Where Electricity is Prohibited (i.e., some underground steam distribution systems, tank farms, etc.)
- Submersible, Hard-To-Get-At Areas.

## HOW IT WORKS

The Pressure Motive Pump uses a spring-loaded mechanism inside a pump body to control liquid removal. When the pump is starting to fill through the inlet check valve the float is in the low level position which opens the vent valve at the top and closes the motive gas (steam or air) supply valve.

When the spring-loaded mechanism reaches the trip point and snaps over the center, the vent valve closes and the gas supply valve opens simultaneously. As the liquid in the body is pumped out through the outlet check valve, the float starts to drop. When the float reaches the switch point, the mechanism snaps over the center, the gas supply valve closes, and the vent valve opens, allowing the filling process to repeat.

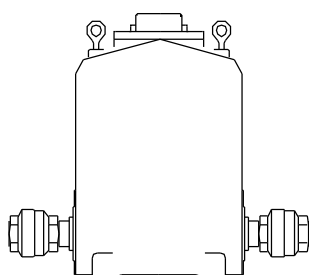

PMPC

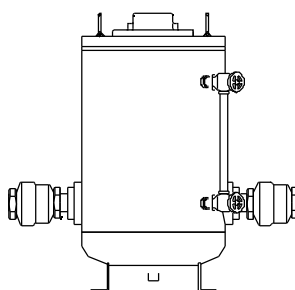

PMPF &amp; PMPSS

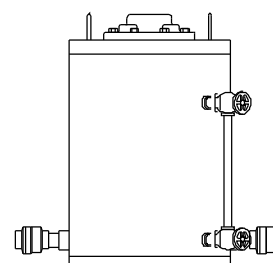

PMPLS

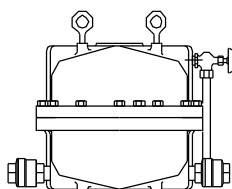

PMPM

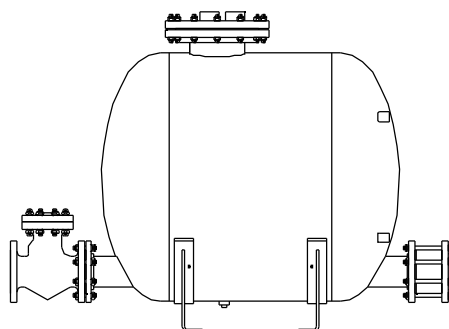

PMPBP

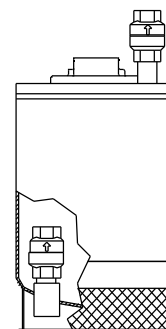

PMPSP

Each Watson McDaniel Company Product is warranted against defects in material and workmanship for one year from date of shipment. This warranty extends to the first retail purchaser only. All defective material must be returned to the person from whom you purchased the Product, transportation prepaid, free of any liens or encumbrances, and if found to be defective will be repaired free of charge or replaced, at the warrantor's or seller's option. If the material is replaced, any replacement will be invoiced in the usual manner and after inspection of alleged defective material an adjustment will be made for depreciation caused by purchaser's use. In no event will Watson McDaniel Company be liable to do more than refund the original contract price. Incidental and consequential damages are excluded, whether under this warranty or otherwise. All implied warranties, including warranties of merchantability and fitness for a particular purpose, are disclaimed and excluded.

**SPECIFICATIONS**

**AVAILABLE OPTIONS**

- Check Valve Sizes for pump inlet and outlet (Sizes 1", 1 1/2", 2", 3" all with screwed ends)
- Gauge Glass Assembly
- Cycle Counter Assembly
- Insulation Cover
- Freeze Protection Drain Line
- Pressure Regulator for Motive Steam or Air
- Supply-1/2" Type O for each pump. For skid-mounted units, consult factory.
- Complete Skid-mounted Unit (including receiver, pump(s) check valves, etc.) all fully piped and ready to use.

**MAX. OPERATING CONDITIONS**

PMPC

PMO 200 PSIG  
TMO 388°F

PMPSS, PMPLS, PMPSP, PMPBP, PMPM

PMO 150 PSIG  
TMO 366°F

PMPF

PMO 250 PSIG  
TMO 406°F

**WEIGHTS**

| Pump Series | (lbs) |
|-------------|-------|
| PMPC        | 390   |
| PMPF        | 240   |
| PMPSS       | 240   |
| PMPLS       | 205   |
| PMPSP       | 235   |
| PMPBP       | 1050  |
| PMPM        | 190   |

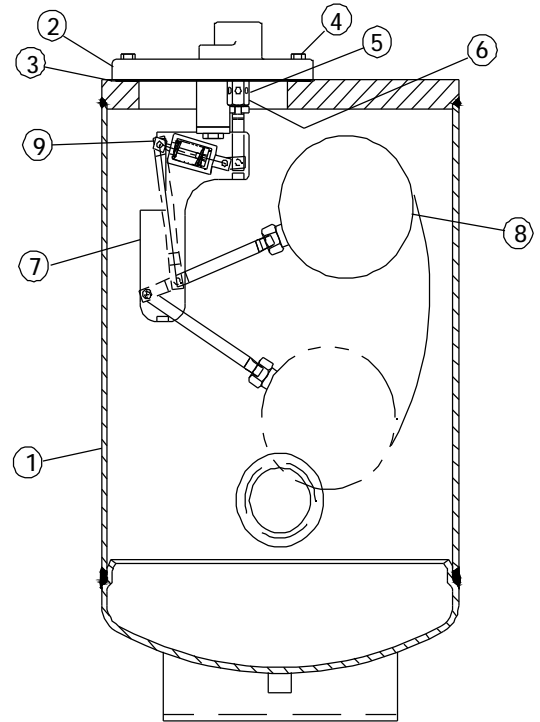

**MATERIALS**

- 1) Body . . . . . Ductile Iron, PMPC  
Cast Iron, PMPM  
304L SST, PMPSS  
Carbon Steel, all other series
- 2) Cover . . . . . Ductile Iron, PMPC  
Cast Iron, PMPM  
Carbon Steel, all other series
- 3) Cover Gasket . . . . . Non Asbestos
- 4) Cover Bolts . . . . . Steel
- 5) Inlet Valve . . . . . 17-4 PH S.ST.
- 6) Vent Valve . . . . . 17-4 PH S.ST.
- 7) Mechanism . . . . . 304 S.ST.
- 8) Ball Float . . . . . 304 S.ST.
- 9) Springs . . . . . Inconel
- 10) Other Internal Comp. . . . . S.ST.
- 11) Check Valves . . . . . S.ST. or Bronze

**PRODUCT WARRANTY**

One year warranty on complete pump.

## INSTALLATION

- The pump must be installed standing in the vertical position and located directly under the equipment to be drained. It is important that the preferred minimum filling head of 12" be established from the top of the pump body to the underside of the receiver (vented system) or reservoir for closed loop system.
- Vented Receiver: A vented receiver should be installed before and above the pressure motive pump. If you will be using an existing tank or fabricated one, be sure to verify that the vessel is properly sized and vented for the application. Please consult our sizing guide on Page 25c of this instruction.
- Closed Loop Reservoir: A reservoir should be installed before and above the pressure motive pump. If you will be using an existing tank or fabricated one, be sure to verify that the vessel is properly sized for the application. Please consult our sizing guide on Page 25d of this instruction.
- Connect the inlet and outlet check valves to the pump. **Caution:** Make sure that the flow arrows on the check valves are oriented in the proper direction. For optimum performance, horizontal pipe runs immediately before and after the check valves should be kept as short as possible. Pipe up the pump inlet check valve to the receiver or reservoir and outlet check to the discharge line. Recommend the use of matching line size, full port isolation valves for the pump.
- Connect the operating supply pressure to the motive inlet connection (1/2" FNPT) at the top of the pump head. Motive pressure line should always be equipped with an isolation valve, strainer and a steam trap, if steam is used and a liquid drainer if air/gas supply is used. The trap condensate discharge should be piped to receiver, reservoir or outlet side of pump.
- Install a pipe line from the vent connection (1" FNPT) at the top of the pump head to receiver or reservoir.

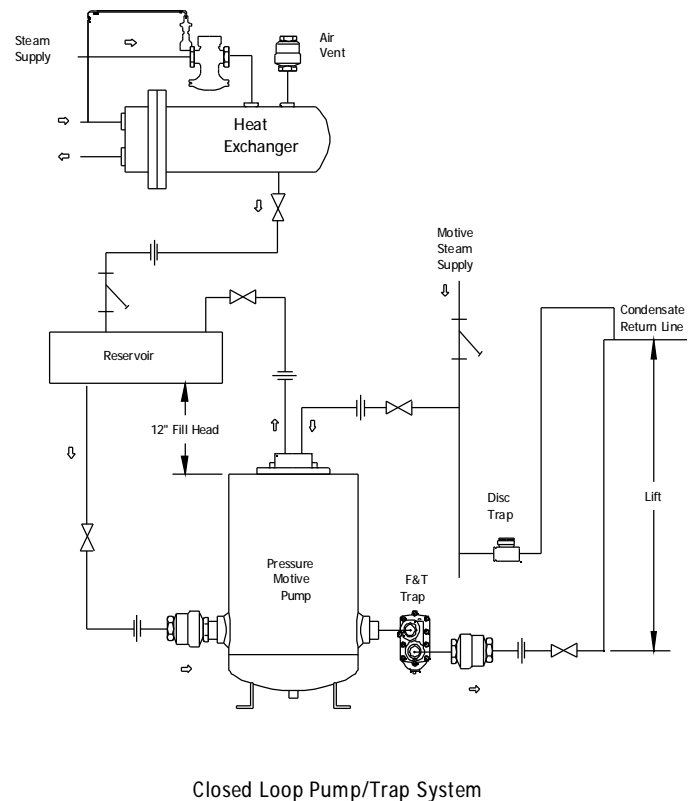
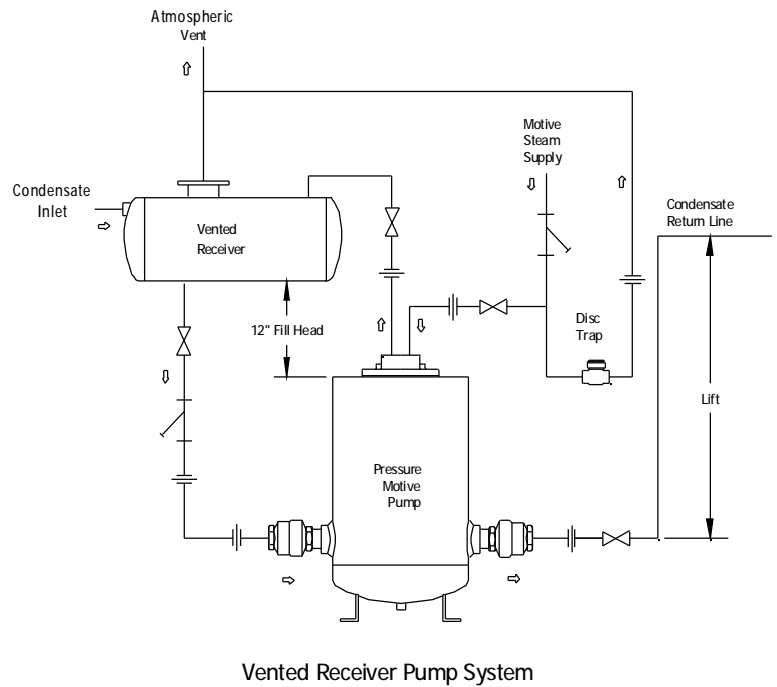

### SIZING VENTED RECEIVER

| Vented Receiver Sizing                             |          |        |                   |
|--|----------|--------|-------------------|
| Flash Steam<br>up to --                            | Receiver |        | Vent<br>Line Dia. |
|  | Dia.     | Length |                   |
| 75 pph   | 4"       | 36"    | 1"                |
| 150 pph  | 6"       | 36"    | 2"                |
| 300 pph  | 8"       | 36"    | 3"                |
| 600 pph  | 10"      | 36"    | 4"                |
| 900 pph  | 12"      | 36"    | 6"                |
| 1200 pph   | 16"      | 36"    | 6"                |
| Below figures are approximate for 4" X 4" Packages |          |        |                   |
| 2000 pph   | 20"      | 60"    | 8"                |
| 3000 pph   | 24"      | 60"    | 8"                |
| 4000 pph   | 26"      | 60"    | 10"               |
| 5000 pph   | 28"      | 60"    | 10"               |
| 6000 pph   | 30"      | 72"    | 12"               |
| 7000 pph   | 32"      | 72"    | 12"               |
| 8000 pph   | 36"      | 72"    | 14"               |

When sizing a Pressure Motive Pump for an atmospheric return system, the amount of flash steam to be vented through the receiver must be calculated. Vent sizing is critical to maintain zero psig in the receiver tank to allow free drainage of low pressure systems. Undersized vents will cause gradual pressure increase in the receiver. This impedes drainage from the condensate source, and can cause waterlogging of the system.

**To Size Receiver & Vent:**

Usually the condensate load to be pumped comes from multiple sources. For each source determine the pressure and load. Then go into the "Percent Flash" table with the condensate pressure and move right until under the appropriate tank pressure to read the percentage of condensate that will flash into steam. Now take that source load and multiply it by the decimal value of the percentage to calculate the amount (lbs/hr) of flash steam. Repeat this for all condensate sources and total the flash steam. Enter the "Vented Receiver Sizing" table with the total flash steam load to determine the correct sizes for receiver and vent.

| Percent Flash Steam<br>Produced when condensate is discharged to atmosphere or into flash tank<br>controlled at various pressures. |                            |      |      |      |      |      |      |      |      |      |      |
|--|----------------------------|------|------|------|------|------|------|------|------|------|------|
| Condensate<br>Pressure (psig)  | Flash Tank Pressure (psig) |      |      |      |      |      |      |      |      |      |      |
|  | 0                          | 2    | 5    | 10   | 15   | 20   | 30   | 40   | 60   | 80   | 100  |
| 5  | 1.6                        | 0.9  | 0.0  |      |      |      |      |      |      |      |      |
| 10   | 2.9                        | 2.2  | 1.3  | 0.0  |      |      |      |      |      |      |      |
| 15   | 3.9                        | 3.3  | 2.4  | 1.1  | 0.0  |      |      |      |      |      |      |
| 20   | 4.9                        | 4.2  | 3.3  | 2.1  | 1.0  | 0.0  |      |      |      |      |      |
| 30   | 6.5                        | 5.8  | 5.0  | 3.7  | 2.6  | 1.7  | 0.0  |      |      |      |      |
| 40   | 7.8                        | 7.2  | 6.3  | 5.1  | 4.0  | 3.0  | 1.4  | 0.0  |      |      |      |
| 60   | 10.0                       | 9.4  | 8.5  | 7.3  | 6.2  | 5.3  | 3.7  | 2.3  | 0.0  |      |      |
| 80   | 11.8                       | 11.2 | 10.3 | 9.1  | 8.1  | 7.1  | 5.5  | 4.2  | 1.9  | 0.0  |      |
| 100  | 13.3                       | 12.7 | 11.8 | 10.6 | 9.6  | 8.7  | 7.1  | 5.8  | 3.5  | 1.6  | 0.0  |
| 125  | 14.9                       | 14.3 | 13.5 | 12.3 | 11.3 | 10.4 | 8.8  | 7.5  | 5.3  | 3.4  | 1.8  |
| 150  | 16.3                       | 15.7 | 14.9 | 13.7 | 12.7 | 11.8 | 10.3 | 9.0  | 6.8  | 4.9  | 3.3  |
| 200  | 18.7                       | 18.1 | 17.3 | 16.2 | 15.2 | 14.3 | 12.8 | 11.5 | 9.4  | 7.6  | 6.0  |
| 250  | 20.8                       | 20.2 | 19.4 | 18.2 | 17.3 | 16.4 | 14.9 | 13.7 | 11.5 | 9.8  | 8.2  |
| 300  | 22.5                       | 21.9 | 21.2 | 20.0 | 19.1 | 18.2 | 16.8 | 15.5 | 13.4 | 11.7 | 10.2 |
| 350  | 24.1                       | 23.5 | 22.8 | 21.7 | 20.7 | 19.9 | 18.4 | 17.2 | 15.1 | 13.4 | 11.9 |
| 400  | 25.6                       | 25.0 | 24.2 | 23.1 | 22.2 | 21.4 | 19.9 | 18.7 | 16.7 | 15.0 | 13.5 |

## SIZING CLOSED LOOP RESERVOIR

| Reservoir Pipe Sizing Closed Loop System |                           |    |      |    |     |     |     |      |     |
|--|---------------------------|----|------|----|-----|-----|-----|------|-----|
| Condensate Load (lbs/hr)                 | Reservoir Pipe Size (NPS) |    |      |    |     |     |     |      |     |
|  | 3"                        | 4" | 6"   | 8" | 10" | 12" | 16" | 20"  | 24" |
| Up to 500                                | 2'                        |    |      |    |     |     |     |      |     |
| 1000                                     | 2'                        |    |      |    |     |     |     |      |     |
| 1500                                     | 3'                        | 2' |      |    |     |     |     |      |     |
| 2000                                     | 3.5'                      | 2' | 1'   |    |     |     |     |      |     |
| 3000                                     |                           | 3' | 2'   |    |     |     |     |      |     |
| 4000                                     |                           | 4' | 2'   | 1' |     |     |     |      |     |
| 5000                                     |                           | 6' | 3'   | 2' |     |     |     |      |     |
| 6000                                     |                           |    | 3'   | 2' |     |     |     |      |     |
| 7000                                     |                           |    | 3'   | 2' |     |     |     |      |     |
| 8000                                     |                           |    | 4'   | 2' |     |     |     |      |     |
| 9000                                     |                           |    | 4.5' | 3' | 2'  |     |     |      |     |
| 10000                                    |                           |    | 5'   | 3' | 2'  | 5'  | 3'  | 2'   |     |
| 20000                                    |                           |    |      |    |     | 10' | 7'  | 4'   |     |
| 30000                                    |                           |    |      |    |     |     | 9'  | 6'   | 4'  |
| 40000                                    |                           |    |      |    |     |     | 12' | 7.5' | 6'  |
| 50000                                    |                           |    |      |    |     |     |     | 9'   | 6'  |

\*When BP/MP is less than 50% these reservoir lengths can be reduced by half.

When sizing Pressure Motive Pumps for closed loop return systems a condensate reservoir should be installed on the inlet side of the pump and below the equipment to be drained. This will enable the condensate to collect while the pump is in the discharge cycle, thus preventing liquid backup into the equipment. The Reservoir Sizing Table gives the minimum pipe size & length to produce the required reservoir volume to accommodate the condensate load.

How to select: Determine the total condensate load to be pumped. Find that load value or greater in the table and move right to read the pipe lengths in feet with the diameters indicated above.

Customized reservoirs can be designed to accommodate specific space, and dimensional requirements. It is critical for these designs to have adequate vapor space for condensate to collect. When the volume required is known, from the previous selection table, optional pipe diameters and lengths can be selected to provide the same or greater volume. This table will allow you to convert required volumes to customized sizes needed. Watson McDaniel can furnish customized Pressure Motive Pump Packages to fit your needs.

## Pipe Sizing Data

| NPS   | Outside Dia. (in) | Schedule 40      |                  |                    |                    | Schedule 80       |                   |                    |                    |
|-------|-------------------|------------------|------------------|--------------------|--------------------|-------------------|-------------------|--------------------|--------------------|
|       |                   | Inside Dia. (in) | Wall Thick. (in) | Flow Area          |                    | Inside Dia. (in.) | Wall Thick. (in.) | Flow Area          |                    |
|       |                   |                  |                  | (in <sup>2</sup> ) | (ft <sup>2</sup> ) |                   |                   | (in <sup>2</sup> ) | (ft <sup>2</sup> ) |
| 1/2   | .0840             | .622             | .109             | .3039              | .00211             | .546              | .147              | .2341              | .00162             |
| 3/4   | 1.050             | .824             | .113             | .5333              | .00370             | .742              | .154              | .4324              | .00300             |
| 1     | 1.315             | 1.049            | .133             | .8640              | .00600             | .957              | .179              | .719               | .00499             |
| 1 1/4 | 1.660             | 1.380            | .140             | 1.496              | .01039             | 1.278             | .191              | 1.283              | .00891             |
| 1 1/2 | 1.900             | 1.610            | .145             | 2.036              | .01414             | 1.500             | .200              | 1.767              | .01227             |
| 2     | 2.375             | 2.067            | .154             | 3.356              | .02330             | 1.939             | .218              | 2.953              | .02051             |
| 2 1/2 | 2.875             | 2.469            | .203             | 4.780              | .03325             | 2.323             | .276              | 4.238              | .02943             |
| 3     | 3.500             | 3.068            | .216             | 7.393              | .05134             | 2.900             | .300              | 6.605              | .04587             |
| 3 1/2 | 4.000             | 3.548            | .226             | 9.887              | .06866             | 3.364             | .318              | 8.888              | .06172             |
| 4     | 4.500             | 4.026            | .237             | 12.73              | .08884             | 3.826             | .337              | 11.50              | .07984             |
| 5     | 5.563             | 5.047            | .258             | 20.01              | .1389              | 4.813             | .375              | 18.19              | .1263              |
| 6     | 6.625             | 6.065            | .280             | 28.89              | .2006              | 5.761             | .432              | 26.07              | .1810              |
| 8     | 8.625             | 7.981            | .322             | 50.03              | .3474              | 7.625             | .500              | 45.66              | .3171              |
| 10    | 10.750            | 10.020           | .365             | 78.85              | .5476              | 9.564             | .593              | 71.84              | .4989              |
| 12    | 12.750            | 11.938           | .406             | 111.9              | .7773              | 11.376            | .687              | 101.6              | .7058              |
| 14    | 14.000            | 13.124           | .438             | 135.3              | .9394              | 12.500            | .750              | 122.7              | .8522              |
| 16    | 16.000            | 15.000           | .500             | 176.7              | 1.227              | 14.314            | .843              | 160.9              | 1.118              |
| 18    | 18.000            | 16.876           | .562             | 223.7              | 1.553              | 16.126            | .937              | 204.2              | 1.418              |
| 20    | 20.000            | 18.814           | .593             | 278.0              | 1.931              | 17.938            | 1.031             | 252.7              | 1.755              |
| 22    | 22.000            | 21.250           | .375             | 354.7              | 2.463              | 19.750            | 1.125             | 306.4              | 2.127              |
| 24    | 24.000            | 22.626           | .687             | 402.1              | 2.792              | 21.564            | 1.218             | 365.2              | 2.536              |

## START-UP PROCEDURE (ALL PUMP PACKAGES)

Gradually open supply (steam, air, or gas) to provide pressure at the pump motive inlet. Make sure the motive trap is operational.

Completely open the full port isolation valves in the pump inlet and outlet lines.

Open gate valve ahead of the pump receiver or reservoir allowing condensate to enter the vessel and begin to fill the pump body below it. Pump will discharge when full.

Carefully observe the PMP unit. The pump(s) should cycle periodically with an audible sound at the end of each pumping cycle. If any irregularities are observed, recheck installation instructions for proper installation, or call the applications engineering department for assistance.

If overflow piping has been provided, check that a water seal has been established to prevent any steam from being vented in normal operation. Prime piping if necessary.

Kit #910-3 Complete Pump Mechanism for PMPC & PMPLS, Kit #900-3 for PMPC, Kit # 900-1 for PMPBP.

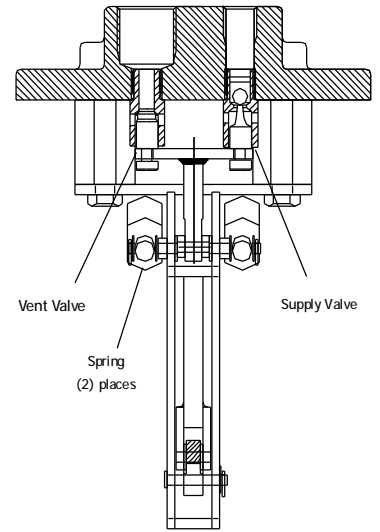

FLOAT BALL NOT SHOWN

## REPAIR & MAINTENANCE

Close all pump isolation valves. Make certain no pressure is trapped in the system. Remove bolts from top cover and lift complete mechanism out of pump body.

Inspect for:

- Wear, dirt and scale on vent, supply, and check valve seat.
- Worn linkage.
- Condition of springs.
- Waterlogged or damaged float.
- Always use a new cover gasket when reassembling.

Kit #900-8 \*Spring assemblies for all pumps except PMPBP  
 Kit #900-4 Cover Gasket for PMPC, PMP, PMPSS, PMPLS & Kit #900-14 PMPBP

COVER GASKET

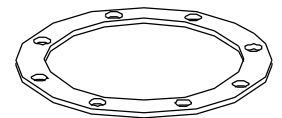

Individual check valves: order by size & material.

INLET CHECK VALVE

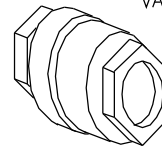

OUTLET CHECK VALVE

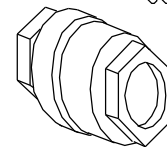

## SPARE PARTS

Kit #900-5 Supply & Vent valve assembly for PMPC, PMP, PMPSS, PMPLS & PMPM  
 Kit # 900-15 for PMPBP

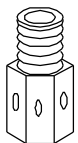

SUPPLY VALVE & SEAT ASSEMBLY



VENT VALVE & SEAT ASSEMBLY

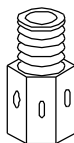

Kit #900-6 Float w/cover gasket for all except PMPBP  
 Kit #900-16 for PMPBP

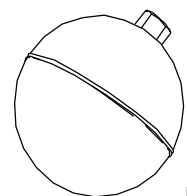

FLOAT

## TROUBLESHOOTING: PRESSURE MOTIVE PUMPS

| PROBLEM   | CAUSE  | ACTION POINT   |
|---|--|--|
| 1. Pump fails to operate on startup.  | <ul style="list-style-type: none"> <li>a. Motive pressure line closed.</li> <li>b. Motive pressure insufficient to overcome backpressure.</li> <li>c. Liquid inlet line closed.</li> <li>d. Liquid discharge line closed.</li> <li>e. Pump air-locked</li> <br/> <li>f. Check valves installed in wrong direction</li> </ul> | <ul style="list-style-type: none"> <li>a. Open valves to supply motive pressure to pump.</li> <li>b. Check motive pressure and backpressure. Adjust motive pressure to 10 psi higher than the backpressure.</li> <li>c. Open all valves to supply liquid to the pump.</li> <li>d. Open all valves on the discharge side of the pump.</li> <li>e. Open System: Make sure that vent line is unrestricted to atmosphere and self draining.<br/><br/>Closed System: Isolate the pump from the pressurized space being drained. (Exhaust tie-back line closed). Break vent connection at pump cover. Stand clear of vent connection. If pump begins to cycle, air locking has occurred. Recheck that exhaust tie-back line is self draining.</li> <li>f. Reverse the check valve(s) to</li> </ul> |
| 2. Liquid backup and equipment flooded, but pump appears to cycle normally. | <ul style="list-style-type: none"> <li>a. Motive pressure is too low to achieve required capacity.</li> <li>b. Insufficient filling head.</li> <li>c. Restriction in liquid inlet line.</li> <li>d. Inlet check valve stuck open.</li> <br/> <li>e. Pump undersized.</li> </ul>  | <ul style="list-style-type: none"> <li>a. Check motive pressure setting and maximum backpressure during operation. Check against sizing table. Increase motive pressure as required.</li> <li>b. Verify required filling head. Lower pump to achieve required filling head.</li> <li>c. Check that only full ported fittings are used. Clean the strainer. Verify that all valves are fully open.</li> <li>d. Isolate inlet check valve and relieve pressure. Remove cap and visually inspect for debris. Clean seating surfaces and reinstall or replace, if necessary.</li> <li>e. Verify rated capacity in the sizing capacity table. Increase check valve size or install additional pump as required.</li> </ul>  |

## TROUBLESHOOTING: PRESSURE MOTIVE PUMPS

| PROBLEM  | CAUSE   | ACTION POINT  |
|--|---|---|
| <p>3. Liquid backup and equipment flooded, and pump has stopped cycling.</p> <p><b>SAFETY NOTE TO PREVENT INJURY:</b> For steps (d) through (g), it is necessary to disconnect the vent line at the pump head. On closed loop systems, be sure that the pump is completely isolated, and pressure is relieved prior to breaking this connection to avoid injury to personnel. Also, it is possible that hot condensate may run out of the vent connection when broken for both closed loop and vented systems.</p> | <ul style="list-style-type: none"> <li>a. Motive pressure low</li> <br/> <li>b. Discharge line closed via valve blocked with debris</li> <br/> <li>c. Outlet check valve stuck closed</li> <br/> <li>d. Inlet check valve stuck closed</li> <br/> <li>e. Motive inlet valve leaking and/or worn</li> <br/> <li>f. Mechanism failure                             <ul style="list-style-type: none"> <li>1. Ruptured float.</li> <li>2. Mechanism binding+</li> </ul> </li> </ul> | <ul style="list-style-type: none"> <li>a. If motive pressure is below backpressure, increase motive pressure setting to 10 psig above backpressure. Do not exceed rated pressure limits of equipment.</li> <br/> <li>b. Compare motive pressure and backpressure. If equal, a closed or blocked discharge line is possible. Check valves downstream of pump.</li> <br/> <li>c. After checking per step 3(b), isolate discharge check valve and relieve line pressure. Remove cap and visually inspect. Clean seating surfaces and reinstall or replace, if necessary.</li> <br/> <li>d. If mechanism is not heard to trip and fluid is not running from the vent connection, it is suspected that the fault lies in the condensate inlet piping. Be sure that all valves leading to the pump have been opened. If so, this indicates that the inlet check valve is stuck closed. Isolate the pump and check valve and relieve line pressure. Remove the cap and visually inspect. Clean seating surfaces and reinstall or replace, if necessary. Reinstall exhaust/tie-back connection and open line.</li> <br/> <li>e. Gradually open motive supply line, leaving the condensate inlet and discharge lines closed. Observe the vent connection for steam or air leakage. If observed, inlet valve is damaged. With pump isolated, remove cover and visually inspect. Replace inlet valve and seat assembly.</li> <br/> <li>f. Keeping motive line open, slowly open condensate inlet line to the pump, allowing pump to fill and observe vent connection. If condensate runs out of vent connection, a mechanism problem is apparent. Isolate pump by shutting off motive supply and condensate inlet, remove cover and visually inspect. Examine float for defects. Stroke mechanism and check for any binding or increased friction. Repair or replace.</li> </ul> |

## TROUBLESHOOTING: PRESSURE MOTIVE PUMPS

| PROBLEM   | CAUSE   | ACTION POINT   |
|---|---|--|
| <p>3. (cont'd)<br/>Liquid backup and equipment flooded, and pump has stopped cycling.</p> | <p>g. Exhaust/tie-back causing vapor lock (vented or closed loop).</p>  | <p>g. If mechanism is heard to trip and no fluid is observed running out of the vent connection, slowly open the discharge line from the pump and observe operation. <u>Keep personnel clear of exhaust connection!</u> If pump cycles normally, a fault in the exhaust/tie-back line is suspected. Recheck the vent/tie-back piping layout for compliance with the installation instructions. Exhaust/tie-back line must be self-draining to prevent vapor locking the pump.</p>  |
| <p>4. Chattering or banging in return main after pump discharges.</p>                     | <p>a. When a pump discharges a significant volume of liquid into a long horizontal return line with rises and drops, the sudden changes in velocity can develop a vacuum.</p> <p>b. Pump is blowing by.</p>       | <p>a. Install a vacuum breaker at high point in return line. For pressurized return systems, an air eliminator may be required down-stream of the vacuum breaker.</p> <p>b. Compare inlet and outlet pump pressure. If the inlet pressure equals or exceeds the backpressure, a "blow through" problem is possible.</p> <p>Open Systems: If trap is leaking steam into inlet piping to the pump, the increased pressure could push the liquid in the pump out the discharge side. Replace bad traps.</p>   |
| <p>5. Vent line discharging excessive flash steam (vented applications only).</p>         | <p>a. Faulty steam traps discharging live steam into condensate inlet line. See also 4(b), Pump is blowing-by.</p> <p>b. Excessive flash steam being vented through pump.</p> <p>c. Vent valve stuck or worn.</p> | <p>Closed Systems: If, under normal operating conditions, the inlet pressure is greater than the return line pressure, and F&amp;T trap should be added to the outlet of pump just before the check valve. The trap will pass the liquid through at the normal higher inlet pressures and allow the pump to normally pressures and allow the pump to normally cycle when low load pump pressures are present.</p> <p>a. Check for leaking traps discharging into condensate return. Repair or replace faulty traps. (See also 4(b), pump is blowing-by).</p> <p>b. Vent receiver or reservoir piping ahead of pump.</p> <p>c. Isolate pump and remove cover and mechanism assembly. Remove exhaust head and seat assembly. Visually inspect seating surface. Clean and reinstall or replace if worn.</p> |

## SIZING & SELECTION: STAINLESS STEEL CHECK VALVES

Liquid Capacity-in lbs/hr using steam as motive media at indicated Filling Head

| Inlet Press | Total Lift | 1" X 1"<br>6" Head<br>PMPLS | 1 1/2" X 1"<br>12" Head | 1 1/2" X 1 1/2"<br>12" Head | 2" X 1"<br>12" Head | 2" X 1 1/2"<br>12" Head | 2" X 2"<br>12" Head | 3" X 2"<br>12" Head | 4" X 4"<br>24" Head | 3" X 2"<br>Duplex | 3" X 2"<br>Triplex | 3" X 2"<br>Quadraplex |
|-------------|------------|-----------------------------|-------------------------|-----------------------------|---------------------|-------------------------|---------------------|---------------------|---------------------|-------------------|--------------------|-----------------------|
| 5           | 2          | 1760                        | 1860                    | 1920                        | 2860                | 3180                    | 3540                | 5000                | 16600               | 10000             | 15000              | 20000                 |
| 10          | 5          | 1870                        | 2200                    | 2450                        | 4350                | 4840                    | 5380                | 7210                | 19000               | 14420             | 21630              | 28840                 |
| 10          | 2          | 2200                        | 3030                    | 3370                        | 6880                | 7650                    | 8500                | 1110                | 22600               | 22220             | 33330              | 44440                 |
| 25          | 15         | 1650                        | 2130                    | 3480                        | 4990                | 5550                    | 6170                | 8230                | 33200               | 16460             | 24690              | 32920                 |
| 25          | 10         | 1980                        | 3600                    | 3990                        | 6560                | 7290                    | 8100                | 10780               | 40300               | 21560             | 32340              | 43120                 |
| 25          | 5          | 2300                        | 4700                    | 5200                        | 7970                | 8860                    | 9850                | 13350               | 46200               | 26700             | 40050              | 53400                 |
| 50          | 40         | 1650                        | 2280                    | 2530                        | 3370                | 3750                    | 4170                | 5670                | 33200               | 11340             | 17010              | 22680                 |
| 50          | 25         | 1980                        | 4050                    | 4500                        | 6800                | 7560                    | 8400                | 11550               | 40100               | 23100             | 34650              | 46200                 |
| 50          | 10         | 2300                        | 4700                    | 5240                        | 7970                | 8860                    | 9850                | 13440               | 47000               | 26880             | 40320              | 53760                 |
| 75          | 60         | 1540                        | 2400                    | 2660                        | 3600                | 4000                    | 4440                | 6340                | 32900               | 12680             | 19020              | 25360                 |
| 75          | 40         | 1980                        | 3780                    | 4190                        | 5920                | 6580                    | 7320                | 9870                | 39400               | 19740             | 29610              | 39480                 |
| 75          | 15         | 2420                        | 5130                    | 5700                        | 8580                | 9540                    | 10600               | 14330               | 47200               | 28660             | 42990              | 57320                 |
| 100         | 80         | 1650                        | 2750                    | 3060                        | 4160                | 4630                    | 5150                | 6860                | 27200               | 13720             | 30580              | 27440                 |
| 100         | 60         | 1870                        | 3600                    | 4000                        | 5560                | 6180                    | 6870                | 9100                | 35100               | 18200             | 27300              | 36400                 |
| 100         | 40         | 2090                        | 4700                    | 5210                        | 6880                | 7650                    | 8500                | 11270               | 42100               | 22540             | 33810              | 45080                 |
| 100         | 15         | 2420                        | 5400                    | 6010                        | 8740                | 9720                    | 10800               | 14330               | 48000               | 28660             | 42990              | 57320                 |
| 125         | 115        | 1430                        | 2380                    | 2640                        | 3270                | 3640                    | 4050                | 4960                | 19500               | 9220              | 14880              | 19840                 |
| 125         | 100        | 1540                        | 2980                    | 3300                        | 4140                | 4600                    | 5130                | 6390                | 25300               | 12780             | 19170              | 25560                 |
| 125         | 80         | 1760                        | 3430                    | 4100                        | 5400                | 6000                    | 6670                | 8540                | 322200              | 17080             | 25620              | 34160                 |
| 125         | 60         | 1980                        | 4170                    | 4850                        | 6600                | 7340                    | 8160                | 10530               | 38500               | 21060             | 31590              | 42120                 |
| 125         | 40         | 2200                        | 5100                    | 6950                        | 7760                | 8630                    | 9590                | 12500               | 44000               | 25000             | 37500              | 50000                 |
| 125         | 15         | 2420                        | 5850                    | 6660                        | 9240                | 10270                   | 11420               | 15100               | 49200               | 30200             | 45300              | 60400                 |
| 150         | 120        | 1590                        | 2650                    | 2940                        | 3400                | 3780                    | 4200                | 5690                | 21600               | 11380             | 17070              | 33760                 |
| 150         | 100        | 1640                        | 2150                    | 3490                        | 4320                | 4800                    | 5350                | 7000                | 29000               | 14000             | 21000              | 28000                 |
| 150         | 80         | 1860                        | 3800                    | 4230                        | 5490                | 6100                    | 6770                | 9100                | 34500               | 18200             | 27300              | 36400                 |
| 150         | 60         | 2080                        | 4500                    | 5000                        | 6660                | 7400                    | 8240                | 11120               | 40300               | 22240             | 33360              | 44480                 |
| 150         | 40         | 2300                        | 5290                    | 5870                        | 7920                | 8800                    | 9780                | 13220               | 44700               | 26440             | 39660              | 52880                 |
| 150         | 15         | 2520                        | 6100                    | 6820                        | 9450                | 10500                   | 11680               | 15500               | 49500               | 31000             | 46500              | 62000                 |
| 175         | 120        | 1680                        | 2870                    | 3150                        | 3580                | 4000                    | 4450                | 5960                | -                   | 11920             | 17880              | 23840                 |
| 175         | 100        | 1770                        | 3370                    | 3720                        | 4500                | 5000                    | 5590                | 7700                | -                   | 15400             | 23100              | 30800                 |
| 175         | 80         | 1980                        | 3960                    | 4470                        | 5680                | 6350                    | 6920                | 9440                | -                   | 19880             | 28320              | 37760                 |
| 175         | 60         | 2210                        | 4740                    | 5240                        | 6900                | 7580                    | 8350                | 11480               | -                   | 22960             | 34440              | 45920                 |
| 175         | 40         | 2420                        | 5600                    | 6040                        | 8150                | 8920                    | 9880                | 13550               | -                   | 27100             | 40650              | 54200                 |
| 175         | 15         | 2630                        | 6260                    | 6970                        | 9750                | 10520                   | 11680               | 15780               | -                   | 31560             | 47340              | 63120                 |
| 200         | 120        | 1800                        | 3090                    | 3350                        | 3720                | 4190                    | 4680                | 6270                | -                   | 12540             | 18810              | 24080                 |
| 200         | 100        | 1810                        | 3600                    | 3940                        | 4680                | 5190                    | 5800                | 8020                | -                   | 16040             | 24060              | 32080                 |
| 200         | 80         | 2100                        | 4160                    | 4660                        | 5820                | 6520                    | 7080                | 9720                | -                   | 19440             | 29160              | 38880                 |
| 200         | 60         | 2330                        | 4950                    | 5450                        | 7080                | 7720                    | 8480                | 11800               | -                   | 23600             | 35400              | 47200                 |
| 200         | 40         | 2530                        | 5790                    | 6220                        | 8400                | 8900                    | 10040               | 13900               | -                   | 27800             | 41700              | 55600                 |
| 200         | 15         | 2740                        | 6440                    | 7080                        | 1000                | 10700                   | 11880               | 16080               | -                   | 32160             | 48240              | 64320                 |

**DIMENSIONS AND TYPICAL APPLICATIONS:  
PRESSURE MOTIVE PUMPS**

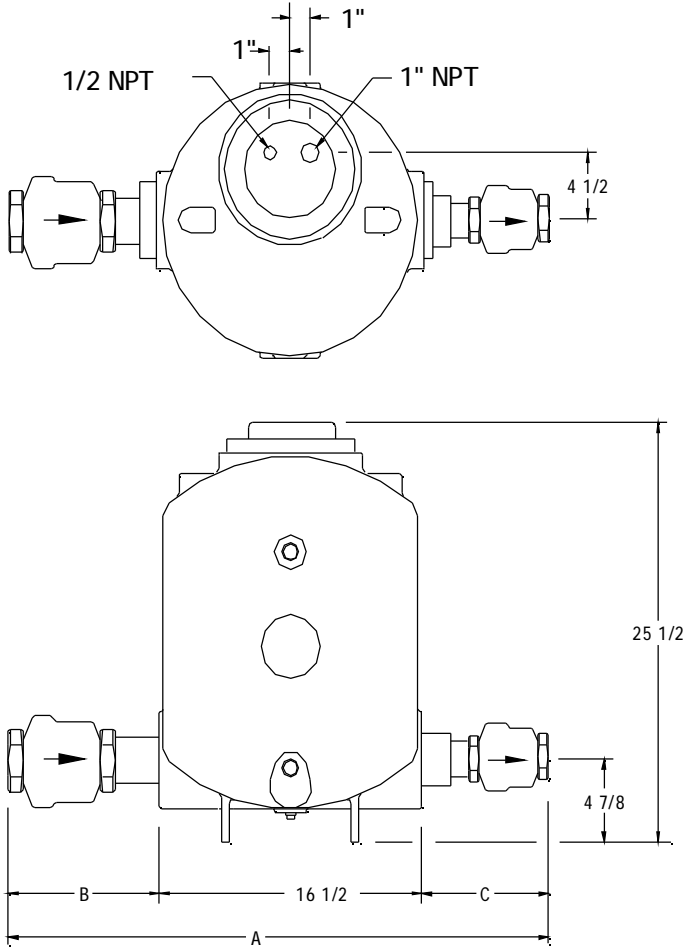

**CLEARANCE DIMENSIONS**

| 'PMP' Size  | A       | B      | C      | Weight |
|-------------|---------|--------|--------|--------|
| 2" X 1"     | 29 7/8" | 7"     | 4 3/8" | 370#   |
| 2" X 1 1/2" | 31 3/4" | 7"     | 6 1/4" | 380#   |
| 2" X 2"     | 32 1/2" | 7"     | 7"     | 385#   |
| 3" X 2"     | 36 1/4" | 9 3/4" | 7"     | 390#   |

\*NOTE: CHECK VALVES HAVE SCREWED END CONNECTIONS

**MATERIALS**

(PMPC) Ductile Iron  
All Stainless Steel Internals.

**SERVICE RANGE**

(PMPC) PMO            200 PSIG  
TMO                      388°F

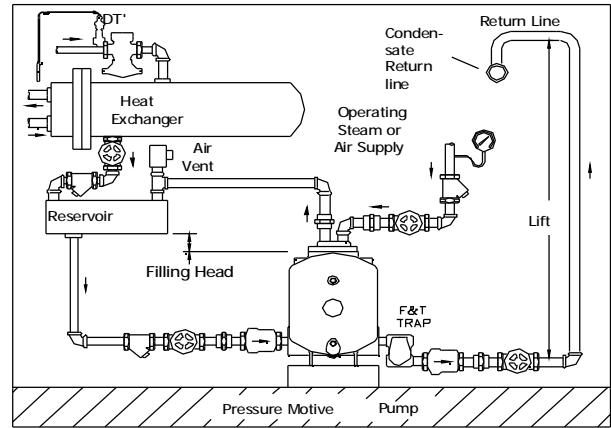

**DRAINING LP HEAT EXCHANGER TO OVERHEAD RETURN**  
(Pressure to Pressure Motive Pump exceeds supply pressure to heat exchanger. Total Lift in PSI is Lift distance in feet x 0.5 PSI/ft, plus pressure drop in return line in PSI, plus pressure drop in condensate return line in PSI)

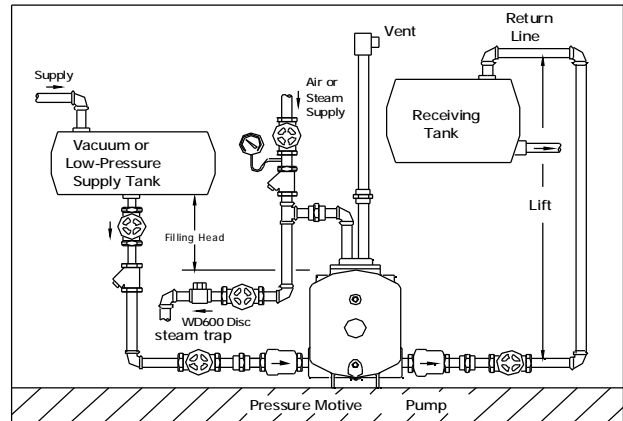

**LIFTING FLUIDS FROM LOW PRESSURE SOURCE TO HIGH-LEVEL RECEIVING TANK**  
(Pressure to Pressure Motive Pump exceeds supply pressure to supply tank. Total Lift in PSI is Lift distance in feet x 0.5 PSI/ft, plus the pressure drop in return line in PSI, plus pressure drop in downstream system components in PSI)

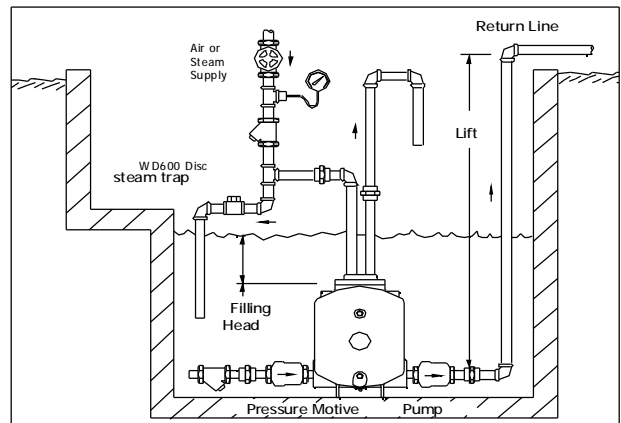

**SUBMERGED 'PMP' LIFTING FLUIDS TO A HIGHER LEVEL**  
(Total Lift in PSI is Lift distance in feet x 0.5 lbs/ft, plus pressure drop in return line in PSI, plus downstream pressure drop in PSI)