



428 Jones Boulevard Phone: (610)495-5131  
 Limerick Airport Business Center Fax: (610)495-5134  
 Pottstown, PA 19464 www.watsonmcdaniel.com

# SERIES 402 & 403

## PRESSURE REGULATOR INSTALLATION & MAINTENANCE INSTRUCTIONS

INSTRUCTION PART NO. 2216500

REVISION 4

**CAUTION:** For continuous service only.  
 Not recommended for seasonal applications.

### INSTALLATION

1. Blow down line thoroughly.
2. Install strainer ahead of valve.
3. Install steam trap ahead of valve.
4. Install regulator in horizontal pipe only. **WARNING:** Vertically installed unit can be erratic and prematurely wear.
5. Install 3/8" sensing line to a point (10 pipe diameters) downstream. Use a needle valve in the pilot line as a control to eliminate pulsations and adjust to provide proper pilot control.
6. Loosen lock nut, then loosen adjusting screw enough to release all tension on the Regulating Valve adjusting spring.
7. Turn on pressure slowly. Then turn down adjusting screw enough to open valve slightly. Operate in this manner for several minutes.
8. Turn down adjusting screw slowly at intervals until desired pressure is obtained. Tighten lock nut.
9. Where pressure is supplied to tank, heater, kettle, etc., the sensing line may be connected directly to point where regulation is desired.

**NOTE:** If Series 402 or 403 is special ordered with internal sensing, the external sensing line is not required.

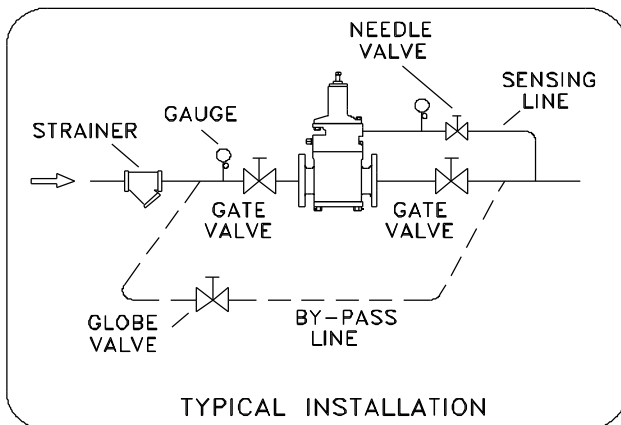

	402	403
MAX. INLET PRESSURE	250 psig	450 psig
MIN. INLET PRESSURE	20 psig	20 psig
MAX. DIFF. PRESSURE	150 psig	250 psig
MIN. DIFF. PRESSURE	10 PSI or 15% of inlet pressure	

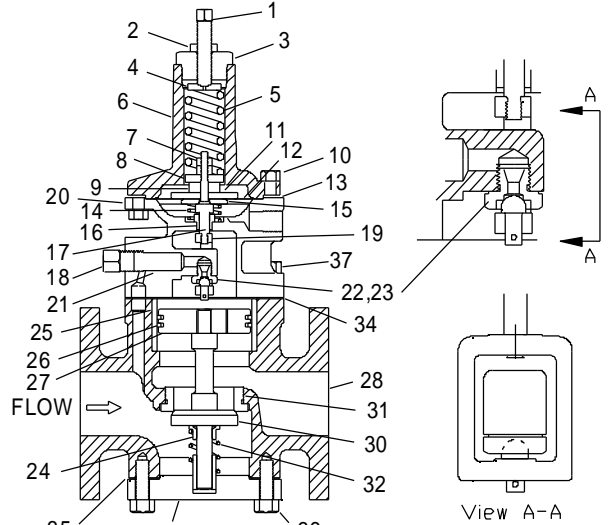

- 1-2 ..... Adjusting Screw & Nut
- 3 ..... Spring Cap (Regulating Cap)
- 4 ..... Spring Washer (Spring Button)
- 5 ..... Adjusting Spring (state range)
- 6 ..... Diaphragm Case (Ductile Iron)
- 7 ..... Stem Nut (2) & Lock Washer
- 8 ..... Upper Stem Guide
- 9 ..... Spacer
- 10 ..... Pilot Bolts
- 11 ..... Top Diaphragm Block
- 12\* ..... Diaphragm Sheets (2)
- 13\* ..... Pilot Diaphragm Gasket
- 14\* ..... Diaphragm Spring
- 15 ..... Bottom Diaphragm Block
- 16 ..... Lower Stem Guide
- 17 ..... Pilot Stem
- 18 ..... Strainer Plug (Bronze)\*\*
- 19 ..... Pilot Yoke
- 20 ..... Pilot Body (Ductile Iron)
- 21\* ..... Strainer Screen
- 22-23\* ..... Pilot Seat & Disc & Cotter Pin
- 24 ..... Bottom Spring Guide (Bronze)\*\*
- 25 ..... Piston Liner
- 26 ..... Piston Rings (2)
- 27 ..... Piston (Bronze)\*\*
- 28 ..... Valve Body (Ductile Iron)
- 30 ..... Disc & Stem Ass'y (Main Valve)
- 31 ..... Seat
- 32 ..... Main Spring
- 33 ..... (1/2" to 1") Bottom Plug Ass'y (Ductile Iron)  
 (1 1/4" to 4") Bottom Cover Ass'y (Ductile Iron)
- 34\* ..... Pilot Body Gasket
- 35 ..... Bottom Cover Gasket
- 36 ..... Bottom Cover Bolts
- 37 ..... Top Cover Bolts

\*Recommended Spare Parts

\*\*403 uses Stainless Steel Wear Parts

Each Watson McDaniel Company Product is warranted against defects in material and workmanship for one year from date of shipment. This warranty extends to the first retail purchaser only. All defective material must be returned to the person from whom you purchased the Product, transportation prepaid, free of any liens or encumbrances, and if found to be defective will be repaired free of charge or replaced, at the warrantor's or seller's option. If the material is replaced, any replacement will be invoiced in the usual manner and after inspection of alleged defective material an adjustment will be made for depreciation caused by purchaser's use. In no event will Watson McDaniel Company be liable to do more than refund the original contract price. Incidental and consequential damages are excluded, whether under this warranty or otherwise. All implied warranties, including warranties of merchantability and fitness for a particular purpose, are disclaimed and excluded.



Remove valve from line.



Remove spring case bolts.



Remove spring case, spring & top diaphragm block.



Remove & inspect diaphragms.



Invert assembly in vise to remove pilot body bolts.



Remove pilot yoke & disc from pilot body.



Remove and inspect pilot seal & pilot strainer.



Remove bottom cover.



Remove disc & stem assembly and main spring & inspect.



Push piston out of body and inspect rings and body bore.



Inspect sealing surface on seat in valve body.



Remove any residual gasket material.

Reassemble after cleaning all threads and sealing surfaces. Apply a high temperature pipe sealant on threads of pilot seat. Install new gaskets. Run a soap bubble test with low pressure air to confirm all seals are good before re installing in service.