



428 Jones Boulevard Phone: (610)495-5131
 Limerick Airport Business Center Fax: (610)495-5134
 Pottstown, PA 19464 www.watsonmcdaniel.com

TYPE 'O'

PRESSURE REGULATOR

INSTALLATION & MAINTENANCE INSTRUCTIONS

INSTRUCTION PART NO. 2220700 CR-3328 REVISION 7

INSTALLATION

1. Blow down line thoroughly.
2. Install strainer ahead of valve.
3. Install steam trap ahead of valve.
4. Install regulator in horizontal pipe only. **WARNING:** Vertically installed unit can be erratic and prematurely wear.
5. Loosen lock nut, then loosen adjusting screw enough to release all tension on the Regulator Valve adjusting spring.
6. Turn on pressure slowly. Then turn down adjusting screw enough to open valve slightly. Operate in this manner for several minutes.
7. Turn down adjusting screw slowly at intervals until desired pressure is obtained. Tighten lock nut.

MAX. INLET PRESSURE 250 PSIG
 MIN. INLET PRESSURE 15 PSIG
 MAX. DIFF. PRESSURE 125 PSI
 MIN. DIFF. PRESSURE 15 PSI

MAINTENANCE

Unsatisfactory regulation is usually due to dirt, pipe compound, etc., blocking the internal strainer or gumming the internal mechanism. To clean strainer, first make sure pressure has been relieved from system. Unscrew bottom plug and remove strainer screen. Clean the lower part of the valve. This can be accomplished without removing the valve from the line or unbolting the cover. If cleaning the strainer does not correct operation, remove valve from line and disassemble parts. After cleaning parts the disc and seat should be lapped together using fine lapping compound. Avoid excessive lapping as this cuts ridges and makes tight seating impossible. Reassemble valve.

PARTS LIST

- 1 Adjusting Screw (includes Lock Nut)
- 2 Adjusting Spring Cap
- 3 Spring Washer
- 4 Adjusting Spring (state range)
- 5 Cover
- 6* Cover Gasket
- 7 Stem Guide
- 8 Upper Diaphragm Plate
- 9* Diaphragm (bronze, 2 sheets)
- 9a* Diaphragm (composition, for water, oil or air)
- 10 Lower Diaphragm Plate
- 11-12 Body Ass'y (includes Seat Insert)
- 13 Disc (includes Lock Nuts)
- 14* Cover Bolts & Nuts, each
- 15* Main Spring
- 16* Strainer Screen (for sizes 1"-2" only)
- 17 Bottom Plug
- 17A Bottom Cover (for 1 1/2" & 2" sizes only)
- 18 Bottom Cover Bolts & Nuts (6)(1 1/2"& 2"only)
- 19* Bottom Cover Gasket (1 1/2" & 2" only)

* Recommended Spare Parts

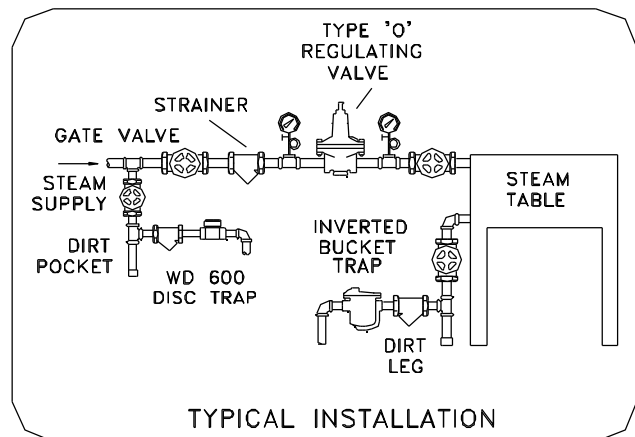
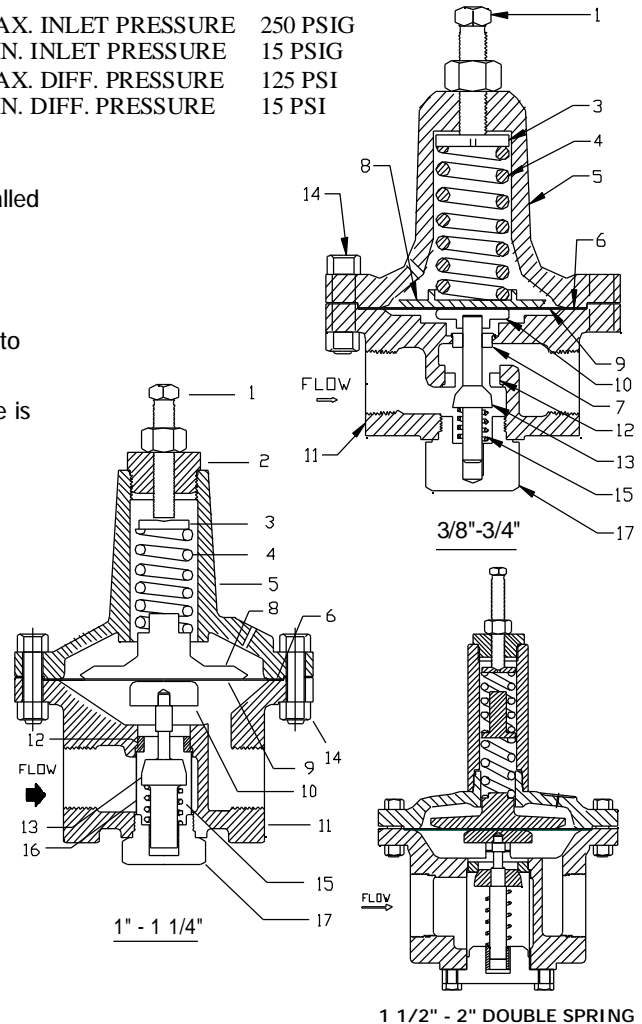

Each Watson McDaniel Company Product is warranted against defects in material and workmanship for one year from date of shipment. This warranty extends to the first retail purchaser only. All defective material must be returned to the person from whom you purchased the Product, transportation prepaid, free of any liens or encumbrances, and if found to be defective will be repaired free of charge or replaced, at the warrantor's or seller's option. If the material is replaced, any replacement will be invoiced in the usual manner and after inspection of alleged defective material an adjustment will be made for depreciation caused by purchaser's use. In no event will Watson McDaniel Company be liable to do more than refund the original contract price. Incidental and consequential damages are excluded, whether under this warranty or otherwise. All implied warranties, including warranties of merchantability and fitness for a particular purpose, are disclaimed and excluded.