



428 Jones Boulevard Phone: (610)495-5131
 Limerick Airport Business Center Fax: (610)495-5134
 Pottstown, PA 19464 www.watsonmcdaniel.com

SERIES 455

INSTALLATION & OPERATING INSTRUCTIONS

INSTRUCTION PART NO. 2227900 REVISION 3

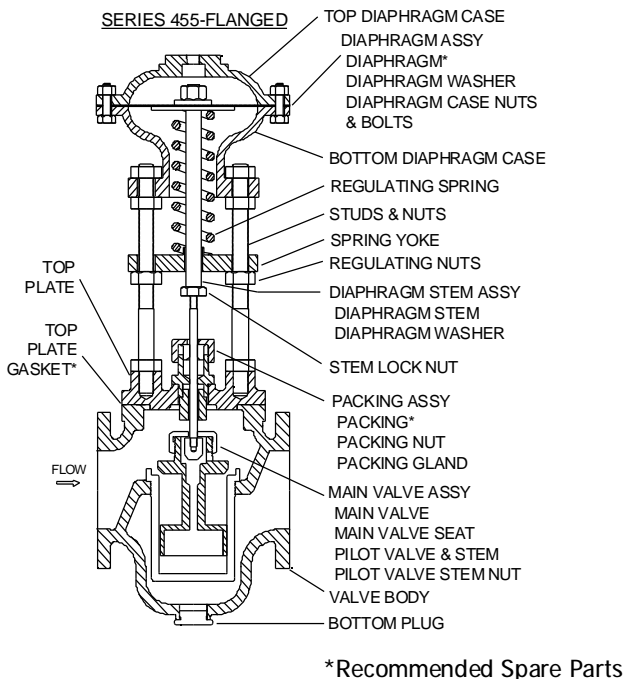
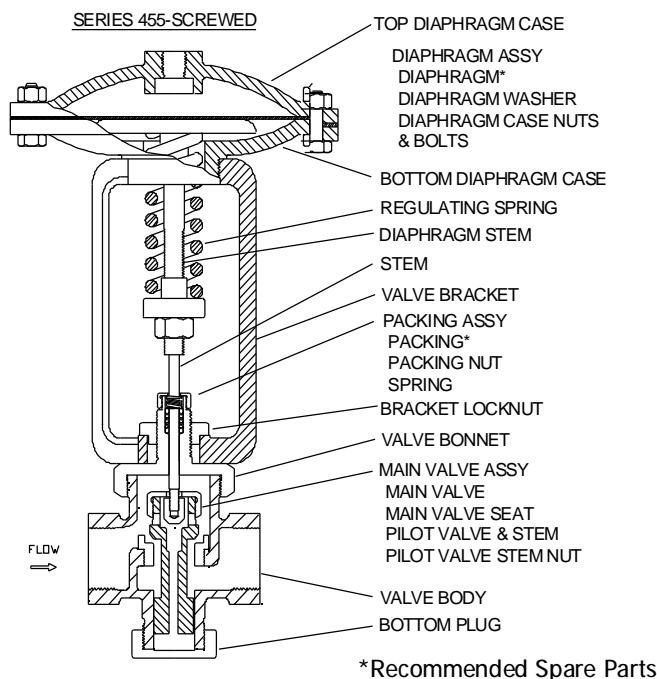

INSTALLATION AND OPERATION

Before installing the pressure regulating valve, be sure to blow out the pipe line to remove all dirt, pipe scale, pipe chips, etc.

Watson McDaniel recommends a 'Y' type strainer be placed in the line on the inlet side of the pressure regulating valve. A bypass line and hand shut off valves and gauges should be installed on either side of the regulating valve as shown in sketch.

Install the Series 455 pressure regulating valve in a straight horizontal run of pipe away from any meters, tees, elbows, etc. which would cause flow turbulence and effect regulation. The flow should be in the direction of the arrow on the body with the diaphragm chamber above the center line of the pipe. However, if head room is scarce, the second best position is to install the valve in an inverted orientation with the diaphragm chamber below the center line of the pipe..

WARNING: The Series 455 valve should not be installed in a vertical run of pipe as the weight of the parts will cause increased wear and subsequently shorten the life of the valve.

Connect a control line from the top of the diaphragm chamber to the top of the piping on the downstream side of the valve. The control line should be installed approximately 10 pipe diameters downstream of the valve in a straight run of pipe away from any flow turbulence. A needle valve should be installed in this control line for the purpose of dampening the response of the valve if required.

On start-up check to see that the by-pass valve is closed and the downstream pressure gauge is reading zero. The upstream pressure

gauge should indicate the line pressure, and the hand valves on the inlet and outlet side of the pressure regulating valve should be full open before adjusting downstream pressure.

The Series 455 pressure regulating valves are diaphragm actuated, spring loaded and are normally open. Increasing the spring compression results in a higher downstream pressure, while decreasing the spring compression reduces the down stream pressure. On start up, slowly increase downstream pressure (on steam wait for the pipe to heat and expand) until the desired pressure is reached.

This instruction sheet is intended as general information and is not to be interpreted as specific information on any particular application. If, after reading the above instructions, you are uncertain as to the product's adaptability for your application, please call factory or authorized representative before installing or using product.

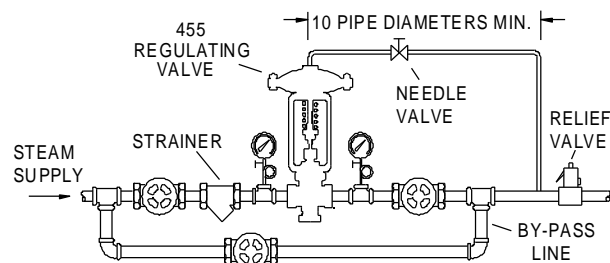

TYPICAL INSTALLATION

Each Watson McDaniel Company Product is warranted against defects in material and workmanship for one year from date of shipment. This warranty extends to the first retail purchaser only. All defective material must be returned to the person from whom you purchased the Product, transportation prepaid, free of any liens or encumbrances, and if found to be defective will be repaired free of charge or replaced, at the warrantor's or seller's option. If the material is replaced, any replacement will be invoiced in the usual manner and after inspection of alleged defective material an adjustment will be made for depreciation caused by purchaser's use. In no event will Watson McDaniel Company be liable to do more than refund the original contract price. Incidental and consequential damages are excluded, whether under this warranty or otherwise. All implied warranties, including warranties of merchantability and fitness for a particular purpose, are disclaimed and excluded.

OPERATING CONDITIONS:

MAX. INLET PRESSURE	250 PSIG
MIN. INLET PRESSURE	5 PSIG
MAX. DIFF. PRESSURE	125 PSIG
MIN. DIFF. PRESSURE	20% of inlet pressure

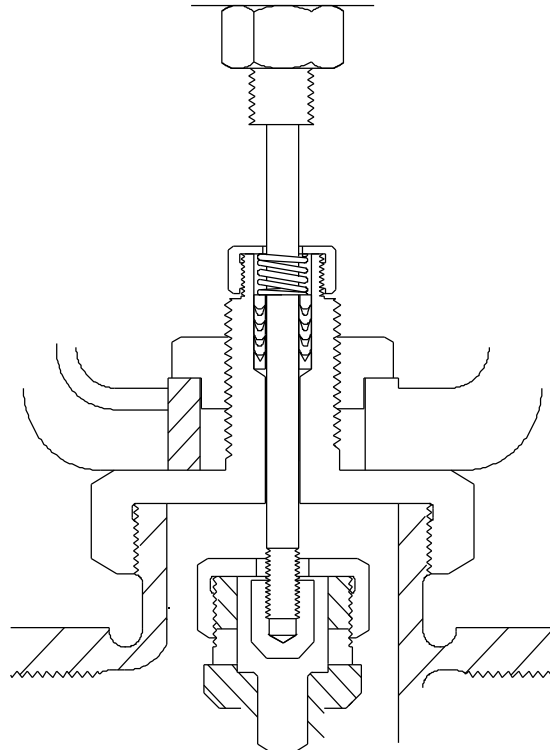
**1/2" - 1 1/2" SERIES 455 INSTRUCTIONS: STEM PACKING REPLACEMENT**

- 1.) Isolate Series 455 from all system pressure. It will be necessary to remove the bracket because the packing is endless. Back off the bracket locknut and unscrew stem from end of diaphragm stem.
- 2.) Remove the actuator-bracket assembly from the valve.
- 3.) Reach down along the Stem with a picking device to pull out all the old Packing Rings. Be careful not to scratch or gouge any of the sealing surfaces.
- 4.) Push the new Packing Rings into place.
- 5.) Slide Spring into place and hand tighten the Packing Nut.
- 6.) Reinstall the bracket-actuator assembly to the stem and valve.
- 7.) Bring the regulator back on line.



Remove valve from line.



Unscrew bonnet.

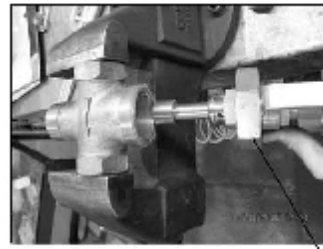

Remove bracket from valve assembly.



Remove top of diaphragm case bolts.



Remove & inspect diaphragm.



Clean diaphragm.



Clean sealing surfaces.



Replace old packing if necessary.



Inspect main valve.



Remove main valve to inspect pilot valve and sealing surfaces.



Clear & inspect body & seat sealing area in body.

Reassemble after cleaning all threads and sealing surfaces. Run a soap bubble test with low pressure air to confirm all seals are good before reinstalling in service.