



428 Jones Boulevard Phone: (610)495-5131
 Limerick Airport Business Center Fax: (610)495-5134
 Pottstown, PA 19464 www.watsonmcdaniel.com

SERIES 153 & 153T

COOLING TEMPERATURE REGULATORS

INSTALLATION & OPERATING INSTRUCTIONS

INSTRUCTION PART NO. 2229700 C.R.3414 REV 5

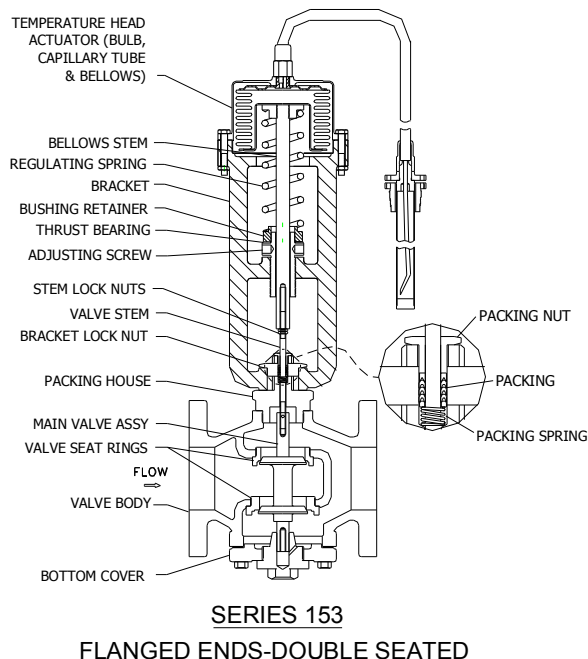
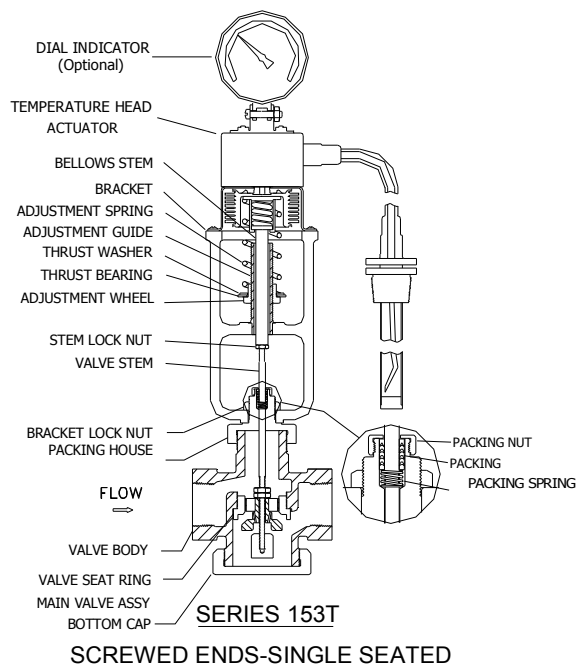

INSTALLATION

After receiving regulator, unpack and inspect to ensure it was not damaged in shipping. The capillary and armor should never be cut, kinked, mashed or twisted. It may be coiled on a 4" radius or larger, but never less than 4".

Caution: When servicing or installing this regulator in a tank, all steam and /or water pressure must be turned off and the tank drained completely. When servicing or installing this regulator in other pressurized vessels, all steam and/or water must be turned off and the lines and vessels relieved of any pressure.

The pipeline must be blown down to ensure scale and foreign particles are removed.

The regulator must be installed with the bellows portion of the temperature head at the highest point in the vertical position. The valve should be installed with flow in direction indicated by the arrow on the body. **Caution: When installing flanged valves make sure flange bolts are tightened evenly to avoid over-stressing and cracking the flanges.**

By-pass connections of the same size as the temperature regulator are recommended. Use gate valves before and after the temperature regulator and a globe valve as the bypass valve. A "Y" strainer must be installed between the inlet side of the regulator and the inlet gate valve. (Make sure sufficient clearance is allowed so the strainer screen can be removed.)

CONNECTING THERMOSTATIC BULB SYSTEM

Remove the (4) bushing screws and remove the bulb bushing from the bulb. Screw the bulb bushing into the selected threaded hole in the tank or pipeline and tighten securely. Then insert the bulb with the bushing gasket onto the bushing and fasten in place with (4) bulb bushing screws.

The bulb must be located in one of the following two positions:

- In the horizontal position with the word 'TOP' stamped on the bulb flange facing upwards.
- In the vertical position, the flange of the bulb must be at the highest point with the bulb pointing downward.

A loop of a few turns of capillary tubing next to the regulator is recommended to absorb vibration from occurring in the pipeline. When installing the bulb, make sure the entire bulb is exposed to the fluid that it will be regulating.

When the sensing bulb is installed in the thermal well, a heat transfer compound must be packed into the socket to increase heat transfer from the liquid to the bulb.

Install an accurate thermometer in the system as close to the thermostatic bulb as possible.

If there is any uncertainty about our product, do not proceed with servicing or installation. Please call the factory or our authorized representative.

Each Watson McDaniel Company Product is warranted against defects in material and workmanship for one year from date of shipment. This warranty extends to the first retail purchaser only. All defective material must be returned to the person from whom you purchased the Product, transportation prepaid, free of any liens or encumbrances, and if found to be defective will be repaired free of charge or replaced, at the warrantor's or seller's option. If the material is replaced, any replacement will be invoiced in the usual manner and after inspection of alleged defective material an adjustment will be made for depreciation caused by purchaser's use. In no event will Watson McDaniel Company be liable to do more than refund the original contract price. Incidental and consequential damages are excluded, whether under this warranty or otherwise. All implied warranties, including warranties of merchantability and fitness for a particular purpose, are disclaimed and excluded.

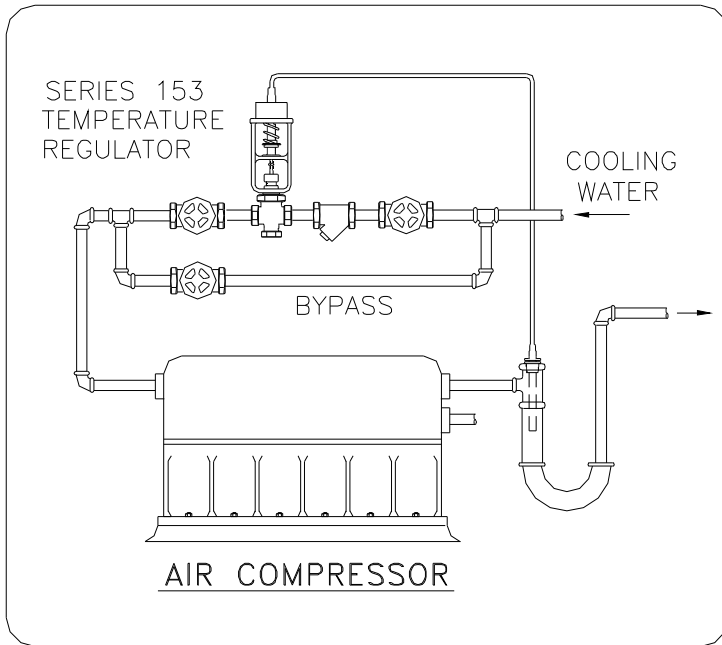

SERVICE INSTRUCTIONS

- 1) Before attempting any service on this regulator make sure of the following:
 - a) All steam and/or water pressure is turned off and the tank (if any) is drained completely. Also, all lines and vessels must be relieved of any pressure at the valve and bulb area.
 - b) Wear heat resistant gloves.
- 2) **READJUSTING BELLOWS STEM HEIGHT**
 - a) The bellows stem height has been factory set and should never be tampered with.
 - b) If inadvertently this setting has been altered, reset as follows:
 - 1) Remove temperature sensing bulb from the media it's sensing.
 - 2) Cool bulb to 30 degrees below the low end of its temperature range.
 - 3) After bulb is cooled, remove thermal head assembly from bracket.
 - 4) Confirm that the main valve assembly is against its seat and then rotate bellows stem assembly until applicable dimension is achieved. (see below)
 - 5) Retighten stem lock nut against end of upper stem.

6) Replace thermal assembly and retest valve operation

3) REPLACING THE THERMAL ASSEMBLY

- a) After Step 1, follow CAUTION LABEL instructions on Temperature Head then loosen the (4) bulb bushing screws slightly.
- b) Wiggle the bulb flange to break gasket connection and ensure that all pressure has been relieved from system.
- c) Remove (4) screws completely and remove bulb from pipe, tank or well.
- d) Remove temperature housing from the bracket by removing eight round head screws.
- e) Install the new thermal assembly in reverse order.

4) SERVICING MAIN VALVE SEAT AND DISC

- a) Consult factory for proper repair kit and any questions regarding this servicing (Double seated valves are not field repairable.)
- b) Shut down system as described in Step 1.
- c) Wait for parts to cool.
- d) Mark valve stem threads right below the stem lock nut, and remove the valve stem and locknut.
- e) Remove packing house.
- f) Pull out main valve disc and inspect disc and main valve seat for wear. On internal pilot operated direct acting regulators, inspect pilot main valve and seat area for same. (Minor wear can be corrected by lapping disc and seat together with 400 grit lapping compound.) Inspect disc(s) and seat(s) for signs of scale or dirt which could have caused leakage. Replace if necessary (Replacement seats and discs should be lapped in.)
- a) Reassemble as required making sure the stem thread mark is right

PMA/TMA

| | |
|-----------|------------------|
| NPT | 250 PSIG @ 450°F |
| 250# Flg. | 250 PSIG @ 450°F |
| 125# Flg. | 125 PSIG @ 450°F |

**UPPER STEM
ADJUSTMENT DIMENSIONS**

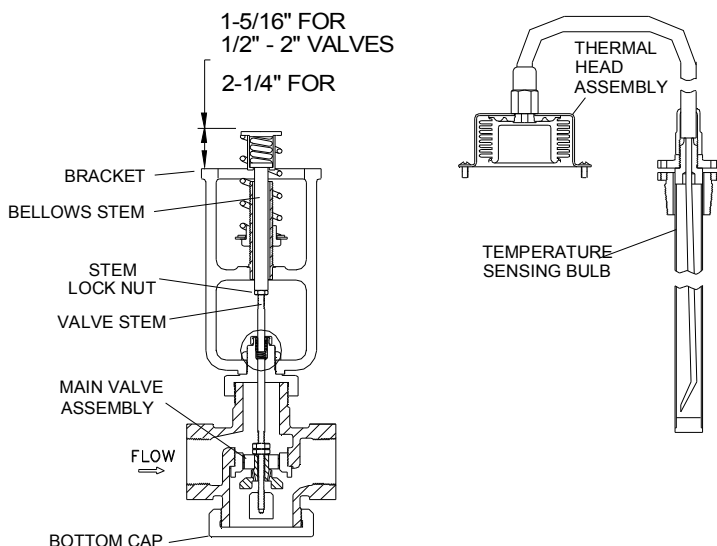

REPLACING VALVE STEM PACKING

- a) Make sure steam supply is safely shut off.
- b) Allow sufficient time for valve to cool.
- c) Remove the bracket/temperature head assembly from valve. This is done by loosening the bracket lock nut, the stem lock nut (make a note of the stem lock nut position relative to the end of the valve stem thread for reassembly) and unscrew the end of the valve stem from the bellows stem. The bracket/temperature head assembly can then be lifted off the valve.
- d) Remove the packing nut, old packing and stem. (It may be necessary to allow a small amount of pressure to build up inside the valve to blow the old packing out of the packing chamber.)
- e) Clean all surfaces of the stuffing box and stem. If the stem is corroded, worn or marred, it must be replaced.
- f) Blow all debris from the stuffing box and the replacement packing. **PACKING MUST BE CLEAN AND FREE OF FOREIGN MATERIAL.**
- g) Install new packing as follows:
NOTE: 'V' rings must be carefully installed over the stem threads and into the stuffing bore to avoid snagging of the lips on threads or the bore entrance. A sharp edge on these lips is imperative for sealing.

- 1) Spring
- 2) Male adapter with flat side in first against spring.
- 3) V-rings with lips first.
- 4) Female adapter with cavity in against V-rings and flat side out.
- 5) Packing nut.

- h) Reinstall bracket over stem and onto packing house
- j) Tighten bracket lock nut and screw valve stem into end of bellows stem (referring to amount of engagement noted during disassembly) and tighten stem nut to stem.

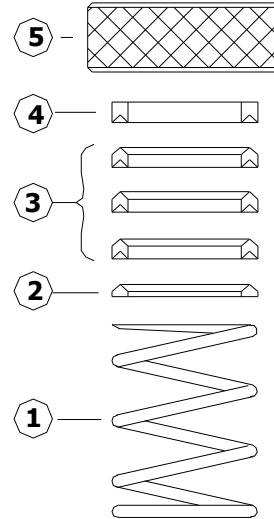

TROUBLESHOOTING

PROBLEM

POSSIBLE CAUSE

CORRECTION

- 1. System will not come up to required temperature.
- 1a. Valve will not open.

- 2. Temperature of system overrides required or set temperature.
- 2a. Valve will not shut.

- a) Valve undersized.
- b) Downstream piping undersized.
- c) Pipe line strainer blocked.
- d) Inlet or outlet gate valve partially closed.
- e) Inlet pressure too low causing reduced capacity through valve.
- f) Packing nut too tight causing stem to bind and not open completely.
- g) Thermostatic bulb not installed in proper location (bulb near a hot spot.)
- h) Condensate not being drained as required.

- i) Dirt lodged between main valve & main valve seat; main valve or seat worn; main valve seat threads leaking; on internal pilot operated direct acting regulators, inspect pilot main valve and seat for the same.

- a) Adjustment nut not set to proper temperature.
- b) By-pass valve open.
- c) Valve is extremely oversized.
- d) Thermostatic bulb not installed in proper location (bulb in cold spot).
- e) Packing nut too tight causing stem to bind and not move from present position.
- f) Thermal system failed.

- a) Check capacity of valve against load.
- b) Check velocity of steam in piping system.
- c) Clean screen.
- d) Open valves.
- e) Check with gage and correct as required.

- f) Make sure packing nut is only hand tight. Replace packing if necessary.
- g) Use a glass thermometer to check temp. throughout system; relocate bulb if necessary
- h) Check to insure that steam trap is installed in proper location and that it is functioning properly.
- i) See service instructions (item 4).

- a) Readjust to desired temperature.
- b) Close valve.
- c) Check catalogue for rated capacities.
- d) Use a glass thermometer to check temp. throughout system & at bulb; relocate bulb if necessary.
- e) Make sure packing nut is only hand tight. Replace packing if necessary.
- f) By controlling manually the flow to the source (heat exchanger, tank etc.) one can watch the stem movement to see if it opens all the way (5/16" on 1/2"-2" and 1/2" on 2 1/2"-6" valves) and if it shuts all the way. If there is a bypass around the temp. regulator with a gate or globe shut off valve you can supply enough steam or water to satisfy the temp. and shut off the valve. If there is a gate or globe shut off valve before or after the temp. regulator you can starve the system by partially shutting these valves and the temp. regulator should open all the way. If there is no or very little movement of the stem during the above tests, the temp. head has probably failed.

- 3. Slow temperature response.

- a) No heat transfer grease in the thermal well.

- a) Fill well with heat transfer grease.