



428 Jones Boulevard Phone: (610)495-5131  
 Limerick Airport Business Center Fax: (610)495-5134  
 Pottstown, PA 19464 www.watsonmcdaniel.com

# SERIES WD600 & WD600S

## THERMODYNAMIC TRAPS

### INSTALLATION INSTRUCTIONS

INSTRUCTION PART NO. 2266700

REVISION 1

## HOW IT WORKS

The Thermodynamic steam trap cycles periodically to discharge condensate very near to steam temperature.

It is unaffected by waterhammer or superheat. An insulating cover minimizes the effect of ambient conditions.

## INSTALLATION

1. Before installing the trap, blow out piping thoroughly to remove loose scale and dirt. Use pipe dope or teflon tape sparingly when attaching the trap to the pipe. Observe the pressure limitation shown on the trap label.
2. Install the trap below the equipment being drained in a location easily accessible for maintenance and inspection. Be certain to install with flow in direction indicated on the trap body.
3. Install a drip pocket to keep dirt out from the trap & to keep from freezing.
4. Discharge piping should be amply sized to avoid excessive back pressures.
5. To provide for easy maintenance and service, install a block valve on each side of the trap and install a strainer ahead of the inlet connection. Strainer must always angle downward.
6. All valves should be full ported to achieve the rated capacity of the trap.
7. If discharge piping is to be elevated, be certain that the available differential pressure is adequate to permit proper drainage. Remember, two feet of lift equals approximately one psi.

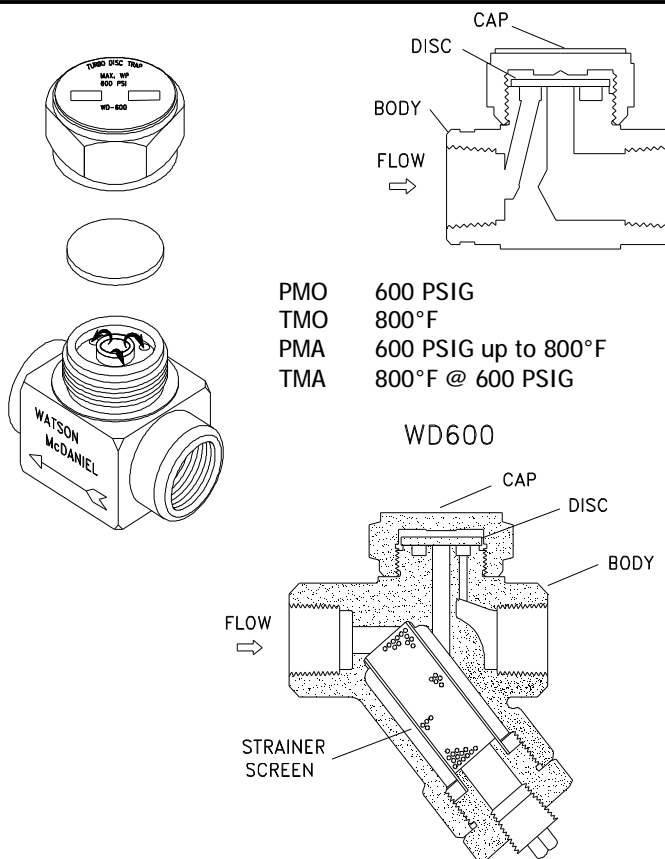

PMO	600 PSIG
TMO	800°F
PMA	600 PSIG up to 800°F
TMA	800°F @ 600 PSIG

WD600

## WD600S TRAP WITH STRAINER IS ALTERNATE TO WYE STRAINER.

PMO	600 PSIG	PMA	915 PSIG up to 250°F
TMO	750°F	TMA	610°F @ 750 PSIG

## ORDERING SPARE PARTS

Specify the description of the part. Indicate the Model Number and Size which are shown on the name plate.

Typical Specification: Disc for 1/2" WD 600 Steam Trap.

## CAP TORQUE IN FOOT-POUNDS

1/2" - 90	3/4" - 90	1" - 90
-----------	-----------	---------

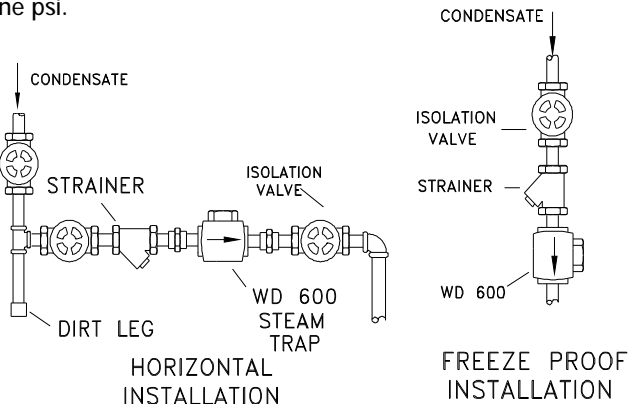

Each Watson McDaniel Company Product is warranted against defects in material and workmanship for one year from date of shipment. This warranty extends to the first retail purchaser only. All defective material must be returned to the person from whom you purchased the Product, transportation prepaid, free of any liens or encumbrances, and if found to be defective will be repaired free of charge or replaced, at the warrantor's or seller's option. If the material is replaced, any replacement will be invoiced in the usual manner and after inspection of alleged defective material an adjustment will be made for depreciation caused by purchaser's use. In no event will Watson McDaniel Company be liable to do more than refund the original contract price. Incidental and consequential damages are excluded, whether under this warranty or otherwise. All implied warranties, including warranties of merchantability and fitness for a particular purpose, are disclaimed and excluded.