



428 Jones Boulevard Phone: (610)495-5131
 Limerick Airport Business Center Fax: (610)495-5134
 Pottstown, PA 19464 www.watsonmcdaniel.com

SERIES HDBP & DBP

PILOT OPERATED BACKPRESSURE VALVE

INSTALLATION INSTRUCTIONS

INSTRUCTION PART NO. 2267400 C.R.-3388 REV. 8

HDBP VALVE

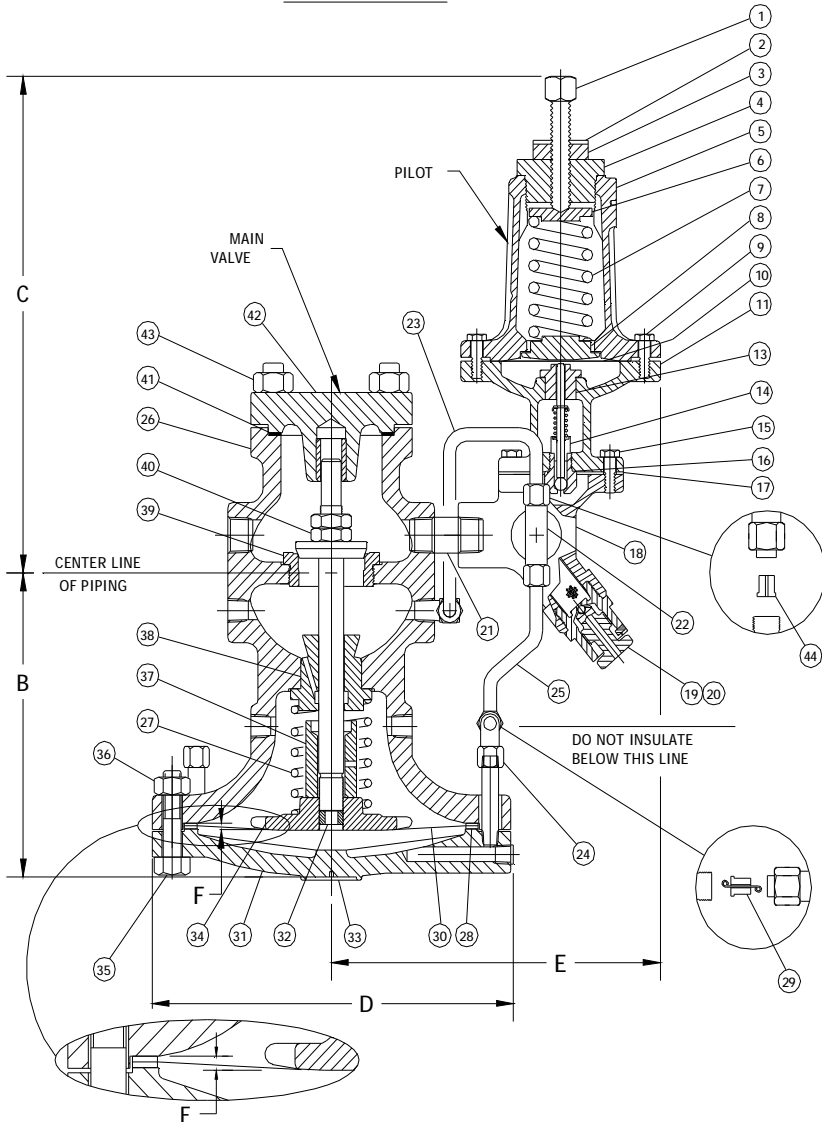

'HDBP' DIMENSIONAL DATA CHART

SIZE	FACE TO FACE		B	C*	D	E**	'HD' F	'D' F	WEIGHT-LB	
	FLANGED								NPT	FLG
	150 PSI	300 PSI								
	NPT									
1/2	4 3/8		5 1/2	11 7/8	6 1/2	7 3/4	.143	.156	18	
3/4	4 3/8		5 1/2	11 7/8	6 1/2	7 3/4	.143	.156	18	
1	5 3/8	5 1/2	6	6 1/4	11 7/8	7	.149	.156	23	35
1 1/4	6 1/2			7 3/8	11 7/8	8 3/4	.175	.125	43	
1 1/2	7 1/4	6 7/8	7 3/8	7 3/8	11 7/8	8 3/4	.175	.140	43	60
2	7 1/2	8 1/2	9	8 1/4	11 7/8	10 7/8	.202	.165	65	85
2 1/2		9 3/8	10	9	11 7/8	11 3/4	.209	.180		105
3		10	10 3/4	8 7/8	11 7/8	13 1/4	.237	.230		145
4		11 7/8	12 1/2	10 7/8	11 7/8	14 3/4	.237	.292		235
6		15 1/8	16	14 1/8	12 1/2	19 3/4	.326	.187		470

LIST OF MATERIALS

PILOT:		
ITEM	PART NAME	MATERIAL
1	Adjusting Screw	Steel
2	Pressure Range Washer	Alum.
3	Lock Nut	Steel
4	Spring Cap	C.R.S. B-1117
5	Pilot Cover	Ductile Iron
6	Upper Spring Plate	H.R.S.
7	Spring	Oil Temp. Stl.
8	Lower Spring Plate Ass'y	H.R.S.
9	Cap Screws	Steel
*10	Diaphragms (2)	Phos. Brz
11	Body, Pilot	Ductile Iron
13	Packing House Bushing	Brass B-16
*14	Head & Seat Ass'y	Stn. Stl.
15	Cap Screw	Steel
*16	Seat Gasket	302 Stn. Stl.
*17	Gasket	Non-Asbestos

MAIN VALVE:		
ITEM	PART NAME	MATERIAL
18	Pilot Adaptor	Ductile Iron
*19	Blowdown Valve	Stn. Stl.
*20	Screen, 40 Mesh	Stn. Stl.
21	Nipple	Black Pipe, Sch.80
22	Male Branch Tee	Brass
23	Tubing, Pilot to Body	Copper Tubing
24	Elbow, Tube to Pipe	Brass
25	Tubing, Pilot to Diaph.	Copper Tubing
26	Main Valve Body	Ductile Iron
27	Spring	302 Stn. Stl.
*28	Gasket, Diaph. Cover	Grafoil
29	Orifice Ass'y, Diaphragm	Brass (Stn. Stl. Wire)
*30	Diaphragm, Main Valve	Phos. Bronze
31	Diaphragm Cover	Ductile Iron
32	Set Screw	Stn. Stl.
33	Name Plate	Stn. Stl.
34	Diaphragm Plate	C.I. A126 Cl. B
35	Cap Screws	Steel
36	Nuts	Steel
37	Plug Stop	Steel Tubing
38	Stem Guide Ass'y	Brass
*39	Seat Ring	402 Stn. Stl.
*40	Disc & Stem Ass'y	Stn. Stl.
*41	Gasket, Cover	Grafoil
42	Cover Assembly	Ductile Iron
43	Nuts	Steel
44	Bleed Orifice, Male Branch Tee	Brass

Note: The 'D' valve is cast iron instead of ductile iron.

- ¹ Must use Factory Replacement Parts for these gaskets
 - ² Not used on 1/2, 3/4 & 1" valves
 - ³ Stem not guided in bottom cover on 1/2, 3/4, & 1" valves
 - * Denotes recommended spare parts
- Specify D or HD valve when ordering.

HDBP Valve Pressure-Temperature Ratings

Screwed Valves	450 PSI @ 650°F
150# Flg. Valves	150 PSI @ 566°F
300# Flg. Valves	450 PSI @ 650°F

DBP Valve Pressure-Temperature Ratings

Screwed Valves	250 PSI @ 450°F
125# Flg. Valves	125 PSI @ 353°F
250# Flg. Valves	250 PSI @ 450°F

Pressure Adjusting Range for Pilot Spring

Pressure	Identifying Color
10-25 PSIG	Yellow
20-100 PSIG	Blue
80-200 PSIG	Red

Note: "Y," "B," or "R" is stamped on top of the pilot to indicate the reduced pressure range of the spring.

Each Watson McDaniel Company Product is warranted against defects in material and workmanship for one year from date of shipment. This warranty extends to the first retail purchaser only. All defective material must be returned to the person from whom you purchased the Product, transportation prepaid, free of any liens or encumbrances, and if found to be defective will be repaired free of charge or replaced, at the warrantor's or seller's option. If the material is replaced, any replacement will be invoiced in the usual manner and after inspection of alleged defective material an adjustment will be made for depreciation caused by purchaser's use. In no event will Watson McDaniel Company be liable to do more than refund the original contract price. Incidental and consequential damages are excluded, whether under this warranty or otherwise. All implied warranties, including warranties of merchantability and fitness for a particular purpose, are disclaimed and excluded.

INSTALLATION

1. Make sure steam supply is safely shut off. Piping hookup Fig. 1 is a typical installation to be used as a guide for planning piping.
2. Valve should be installed in horizontal position with flow in direction as indicated by arrow on body. Main valve diaphragm to be in down position. Caution: When installing flanged valves make sure flange bolts are tightened evenly so as not to overstress and crack flanges.
3. Piping on downstream side of valve is generally larger than valve to eliminate flow restriction.
4. Line should be blown down thoroughly.
5. By-pass connections of same size as pressure reducing valve is recommended. (See Fig. 1.) Use gate valves before and after pressure reducing valve and globe valve as by-pass valve.
6. Install a steam trap in a drip leg ahead of the pressure reducing valve to remove the condensate, insure proper operation and increase valve life.
7. A 'Y' type strainer should be installed before the pressure reducing valve. Make sure sufficient clearance is allowed so strainer screen can be removed.
8. Assemble Pilot to Main Valve:
 - a) Remove pilot adaptor protector from main valve.
 - b) Place gasket on pilot adaptor making sure roll pin in pilot adaptor is inserted thru small hole in gasket.
 - c) Assemble pilot to adaptor making sure roll pin in adaptor is inserted in blind hole assembly. Tighten bolts evenly.
9. Pilot line connections.
 - a) Pilot sensing line should be either 1/4" pipe or 5/16 O.D. copper tubing.
 - b) Pilot sensing line to be connected from pilot valve to the upstream piping, ten pipe diameters from pressure reducing valve and in an area where there will be a minimum amount of turbulence. (If pilot is moved to opposite side of valve the tubing must be rearranged to connect to downstream piping.)
 - c) To keep condensate out of pilot valve the pilot line should be sloped downward away from valve.
 - d) When reduced pressure is supplied to a single piece of equipment such as a tank, heater, kettle, etc. the pilot line may be connected directly to the point where regulation is desired.
 - e) A needle valve should be installed in the pilot line so valve can be isolated for service.
 - f) A pressure gage should be installed in the pilot line connection in the upstream piping. (Use condensate loop & gage valve.)
 - g) A union should be installed near the pilot body so pilot can be easily serviced.

START UP

1. Make sure all lines have been blown down to remove initial dirt and scale from system.
2. Close all valves in installation.
3. Loosen locknut on pilot, then loosen adjusting screw enough to release all tension on adjusting spring.
4. Open valve ahead of steam trap or other drain valve to make sure all condensate is drained from inlet piping. If this is not done, serious damage to the piping system can occur as a result of water hammer.
5. After all condensate is removed open valve in pilot line.
6. Open down stream gate valve. Bypass, if installed, should be closed.
7. Open inlet gate valve slowly. Watch for possible water hammer.
8. Turn pilot adjusting screw slowly clockwise until valve opens and passes steam. Adjust pilot spring until desired upstream pressure is obtained. A time period may be involved to fill the downstream pipe system with steam before adjusting spring can be adjusted for correct pressure setting.
9. After system has stabilized readjust spring setting to obtain exact desired pressure and tighten adjusting screw locknut.
10. Inspect all piping connections and valve for possible leaks and tighten as required. Check and retighten main valve diaphragm bolts.

MAINTENANCE

It is a good practice to periodically inspect and clean the following parts. Frequency of inspection and cleaning are dependent on the condition of the steam system.

1. Blow down or clean all pipe line strainer screens.
2. Inspect and clean pilot screen (20).
3. Inspect and clean bleed and diaphragm orifice.
4. Check all connections for leakage.

Note: These items should also be checked a few days after valve is initially installed and shortly after start-up during each heating season.

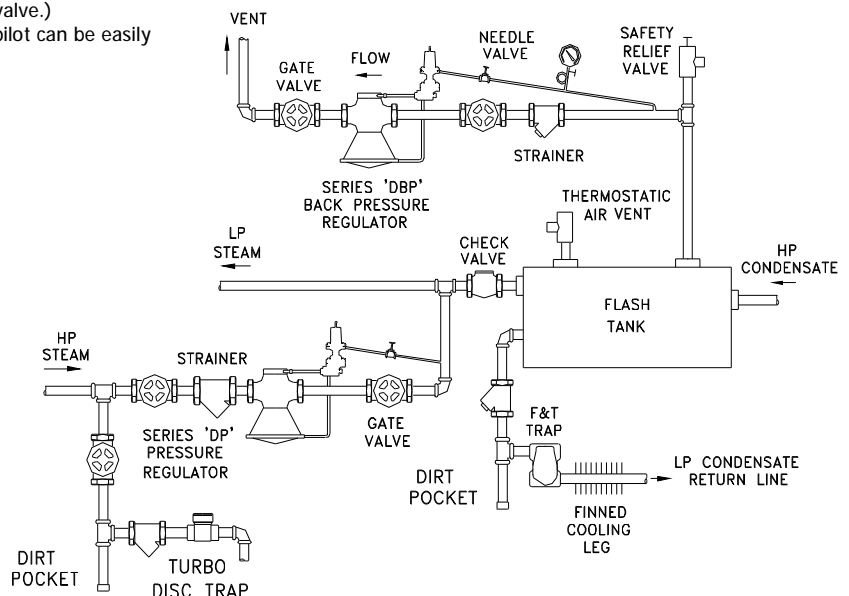

(FIG. 1) FLASH TANK STEAM RECOVERY

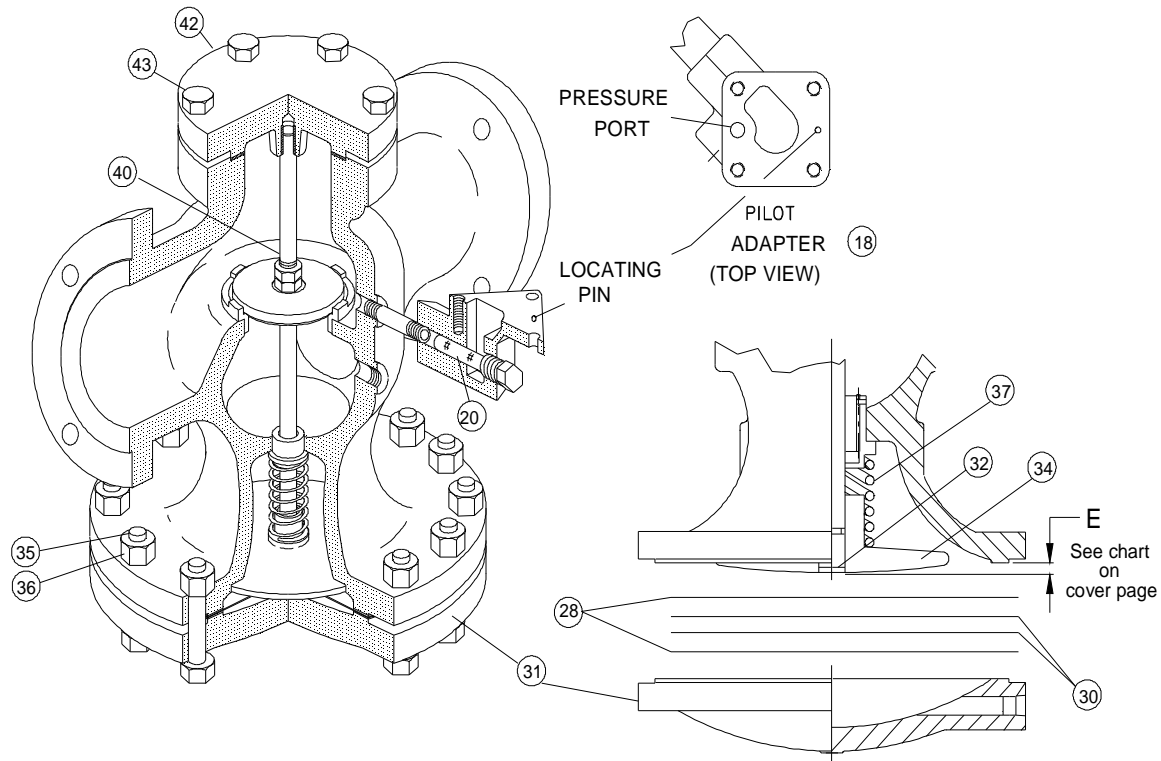

SERVICING INSTRUCTIONS: MAIN VALVE

CAUTION - Regulator & pilot must be cool before disassembly.

1.) Servicing main valve diaphragms (30) .

- a) Shut off inlet gate valve and make sure downstream pressure is zero. Downstream gate valve could also be shut when pressure is at zero to prevent any downstream condensate from entering the valve.
- b) Disconnect copper tubing to diaphragm chamber at 'A' check diaphragm orifice (29) for damage, etc. **CAUTION:** Some hot condensate may leak from line and diaphragm chamber.
- c) Loosen main valve diaphragm nuts (36) . **CAUTION:** Chamber filled with condensate which could be hot. First slightly loosen nuts, then further loosen several nuts on opposite side from where you are standing. Pry cover from valve allowing condensate to drain from valve away from you. Gently pry diaphragm loose from body to drain condensate from body of valve.
- d) Remove all bolts and diaphragm cover (31) .
- e) Inspect the two (2) metal diaphragms (30) for small cracks and wrinkles. Replace if necessary.
- f) Clean diaphragm, diaphragm plate and gasket surfaces before reassembly
- g) Make sure diaphragm plate (34) is securely fastened to stem with locking set screw. Check diaphragm plate setting. See dimension 'E' above.
- h) Valve stem assembly (40) can be checked for proper movement by pushing up on diaphragm plate. **CAUTION:** Condensate may be in upper portion of body.
- i) Replace diaphragm gaskets (28) if necessary. Use only factory replacement gaskets.
- j) Center diaphragms and gaskets on cover. Bolts will assist in centering.
- k) Assemble making sure bolts are taken-up evenly. After system is started check bolts again for tightness.

2.) Servicing main valve disc and seat.

- a) Follow disassembly instructions as noted in diaphragm servicing instructions, a) above.
- b) Loosen diaphragm plate set screw (32) and remove diaphragm plate (34).
- c) Remove bottom cover bolts (43) and cover (42).
- d) Remove stem and disc assembly from valve and inspect disc and seat for wear. Minor wear can be corrected by lapping disc and seat together with 400 grit lapping compound. Inspect the disc and seat for signs of scale or dirt which could have caused leakage.
- e) Check for body erosion around seat ring. Check seat ring for possible damage or excessive wear and any signs of scale or dirt which could have caused leakage. Replace if necessary. Replacement seats and discs should be lapped.
- f) Reassemble as required. Make sure plug stop (37) is installed properly.

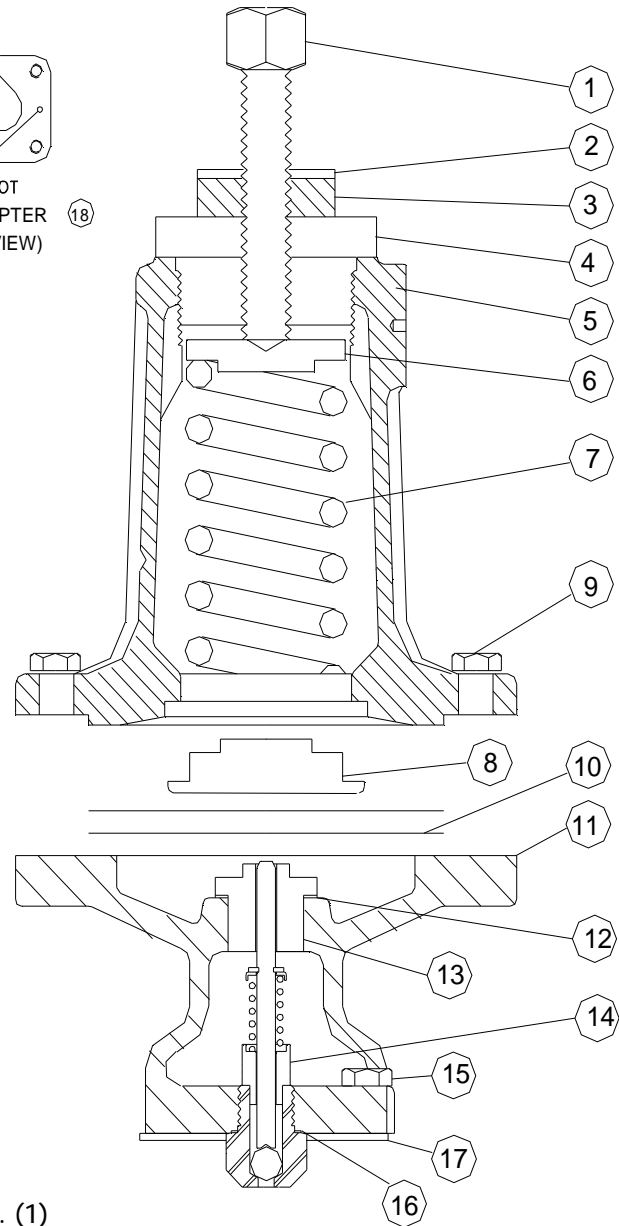
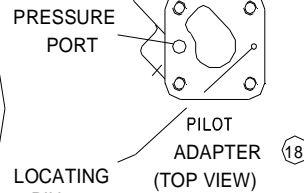
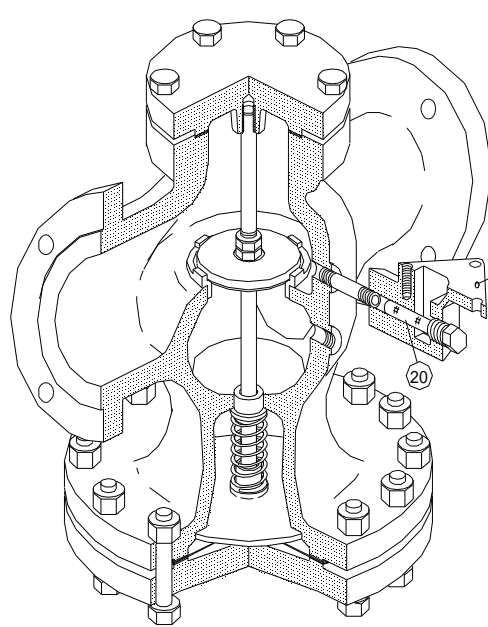

LIST OF MATERIALS

PILOT:		
ITEM	PART NAME	MATERIAL
1	Adjusting Screw	Steel
2	Pressure Range Washer	Alum.
3	Lock Nut	Steel
4	Spring Cap	C.R.S. B-1117
5	Pilot Cover	Ductile Iron
6	Upper Spring Plate	H.R.S.
7	Spring	Oil Temp. Stl.
8	Lower Spring Plate Ass'y	H.R.S.
9	Cap Screws	Steel
*10	Diaphragms (2)	Phos. Brz
11	Body, Pilot	Ductile Iron
13	Packing House Bushing	Brass B-16
*14	Head & Seat Assy	Stn. Stl.
15	Cap Screw	Steel
*16	Seat Gasket	302 Stn. Stl.
*17	Gasket	Non-Asbestos

SERVICING INSTRUCTIONS: PRESSURE PILOT

1.) Servicing pilot valve diaphragm. (10)

- Tighten pilot adjusting screw until valve fully closes. (1)
- Shut off inlet gate valve. Down stream pressure should be zero.
- Remove pilot cover cap screws (9) and cover. (5)
- Inspect the metal diaphragms (10) for cracks and wrinkles. Replace diaphragms if necessary.
- Clean dirt from inside pilot assembly and diaphragm surfaces. Recommend a bead of Teflon pipe sealant be applied to pilot body (11) diaphragm cavity.
- Reassemble as required making sure bolting is taken-up evenly.
- Suggest pilot adaptor screen (20) be checked at this time.

2.) Servicing pilot seat and disc assembly.

- Shut down system as required. Disconnect sensing line from pilot.
- Loosen tension on pilot adjusting spring. (7)
- Remove pilot assembly from pilot adaptor by removing cap screws. (15)
- Screw out the pilot head and seat (14) which is one complete cartridge assembly.
- Inspect, if any wear or damage is noted, replace complete assembly.
- Before reinstalling pilot head and seat assembly, inspect packing house bushing (13) for possible binding of pilot stem and excessive clearance between guide and stem. Replace only if necessary.
- Reassemble as required. Inspect male branch tee orifice (44).

TROUBLESHOOTING GUIDE FOR SERIES "HD" & "D" REGULATORS

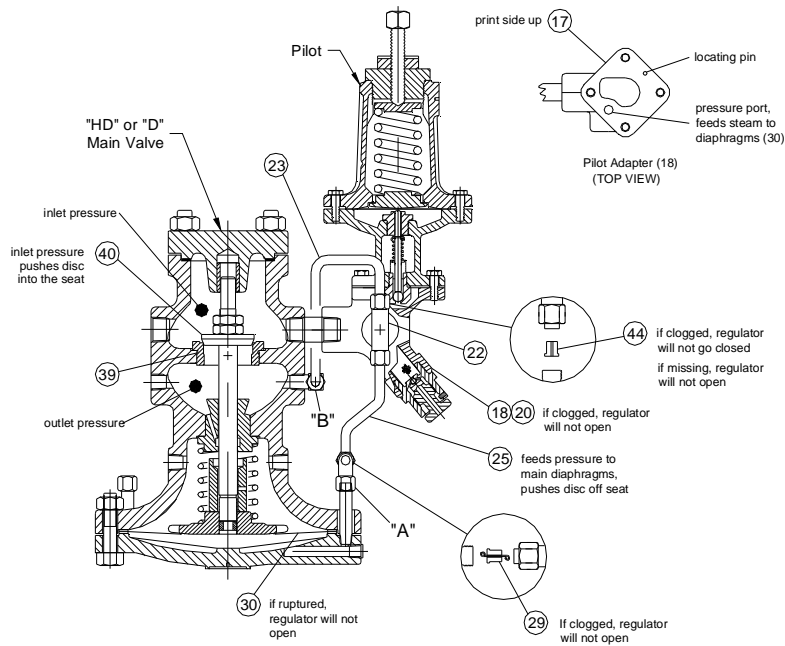

IMPORTANT NOTE:

By far the most common field problem with 'HD' & 'D' valves is that they become saturated with condensate or water. 'HD' & 'D' valves are designed to operate on steam and may perform erratically or fail to operate at all if the valve and/or pilot contain water. You should always make certain all water is drained from the valve and pilot first before trying to troubleshoot a malfunctioning 'HD' & 'D' valve.

PRESSURE OVERRIDES SET POINT

1. Shut off inlet gate valve to regulator and make sure downstream pressure is zero.
2. Make sure that the Pilot Gasket (17) is properly oriented on the Pilot Adapter (18); otherwise, the pressure port in the adaptor will be blocked and regulator will not open.
3. Check Pilot Strainer (20) for blockage as well as the upstream pipeline strainer.
4. Inspect Diaphragm Orifice (29) for blockage and Diaphragms (30) for rupture.
5. Check that the Bleed Orifice (44) at the Male Branch Tee (22) is not missing.

REGULATOR WILL NOT COME UP TO PRESSURE: ISOLATE REGULATOR FROM PILOT FOR TESTING

1. Shut off inlet block valve to regulator and make sure downstream pressure is zero.
2. Adjust the pilot to the closed position. If it is a Pressure pilot, back out the adjustment screw until there is no compression on the spring. If a Temperature pilot, turn the

temperature adjusting knob to the lowest setting.

3. Disconnect the pilot tube (25) at the regulator diaphragm which is indicated as point "A" in the illustration above. Also disconnect the smaller pilot tube (23) at the side of the regulator body designated point "B" in the above illustration.
4. Stand clear of the tube connections and open the block valve upstream of the Main Valve only partially to limit the steam pressure to the regulator. Full line pressure is not necessary for this test.
5. Regulator seat test - With the long pilot tube disconnected at point 'A' the regulator should be closed. If there is steam blowing out of the body side connection at point "B", the main valve and seat are leaking and require inspection for debris that is holding the valve off the seat or erosion of the sealing surfaces.
6. Pilot seat test - With the pilot closed there should not be any steam coming out of the long tubing at point "A". If there is steam flow, the pilot is not closing off and must be inspected for debris or seat erosion. Try running the adjustment screw in & out a few times to clear the debris. If that is not successful, the pilot must be cleaned, repaired or replaced.

SYSTEM TROUBLESHOOTING

PROBLEM	POSSIBLE CAUSE	CORRECTION
1 Upstream pressure overrides set pressure under load conditions.	<ul style="list-style-type: none"> a) Valve undersize. b) Downstream piping undersize. c) Pilot valve spring not adjusted properly. d) Pilot adjusting spring not correct. e) Inlet or outlet gate valve partially closed. f) Upstream pipeline strainer blocked. g) Pilot screen clogged. h) Inlet pressure too low causing reduced capacity thru valve. i) Diaphragm orifice blocked. j) Bleed orifice fitting missing, installed wrong or eroded. k) Main valve diaphragm failed. 	<ul style="list-style-type: none"> a) Check capacity of valve against load requirements. b) Check velocity of steam in piping system. c) Readjust desired reduced pressure. d) Check color code of spring against spring range in literature. e) Open valves. f) Clean strainer screen. g) Clean screen. h) Check with gage and correct as required. i) Check and clean orifice. Do not remove clean-out wire. j) Inspect and check against cut-away drawing. k) Replace diaphragms.
2. Cannot set valve to give high enough upstream pressure.	<ul style="list-style-type: none"> a) Valve is extremely oversized. b) Bypass valve open. c) Pilot valve adjusting spring set too high. d) Bleed orifice blocked. e) Dirt in pilot seat or stem guide. f) Foreign object lodged between main valve disc and seat. g) Pilot diaphragms ruptured. h) Main valve seat thread leaking. 	<ul style="list-style-type: none"> a) Check catalog for rated capacities. b) Close valve. c) Readjust to desired reduced pressure. d) Inspect and clean. e) Clean pilot head and seat assembly. f) Check main valve disc and seat. Check stem guide bushing for binding. g) Replace pilot diaphragms. h) Check body in seat ring area for erosion.
3. Valve will not open.	<ul style="list-style-type: none"> a) Adjusting spring not set. b) Upstream isolation valve closed. c) Upstream pipeline strainer blocked. d) Pilot screen blocked. e) Pilot adapter gasket installed wrong. f) Pilot stem and guide bound with dirt. g) Bleed orifice missing or installed wrong. h) Diaphragm orifice blocked. i) Main valve diaphragms ruptured. 	<ul style="list-style-type: none"> a) Adjust setting. b) Check and open valve. c) Clean strainer screen. d) Remove and clean. e) Install gasket correctly. See cut-away drawings. f) Inspect and clean. g) Inspect and check against cut-away drawing. h) Inspect and clean. Do not remove clean out wire. i) Replace main valve diaphragms.
4. Valve will not close.	<ul style="list-style-type: none"> a) Bypass valve open. b) Pilot sensing line not installed. c) Bleed orifice blocked. d) Dirt in pilot seat or guide. e) Pilot diaphragms ruptured. f) Foreign object lodged between main valve disc and seat. 	<ul style="list-style-type: none"> a) Close bypass valve. b) Install pilot sensing line. c) Inspect and clean. d) Inspect and clean. e) Replace pilot diaphragms. f) Inspect, clean and repair.