



428 Jones Boulevard Phone: (610)495-5131
 Limerick Airport Business Center Fax: (610)495-5134
 Pottstown, PA 19464 www.watsonmcdaniel.com

SERIES HDT & DT

TEMPERATURE PILOT REGULATING VALVE

INSTALLATION INSTRUCTIONS

INSTRUCTION PART NO. 2316100 C.R.-3388 REV. 5

HDT VALVE

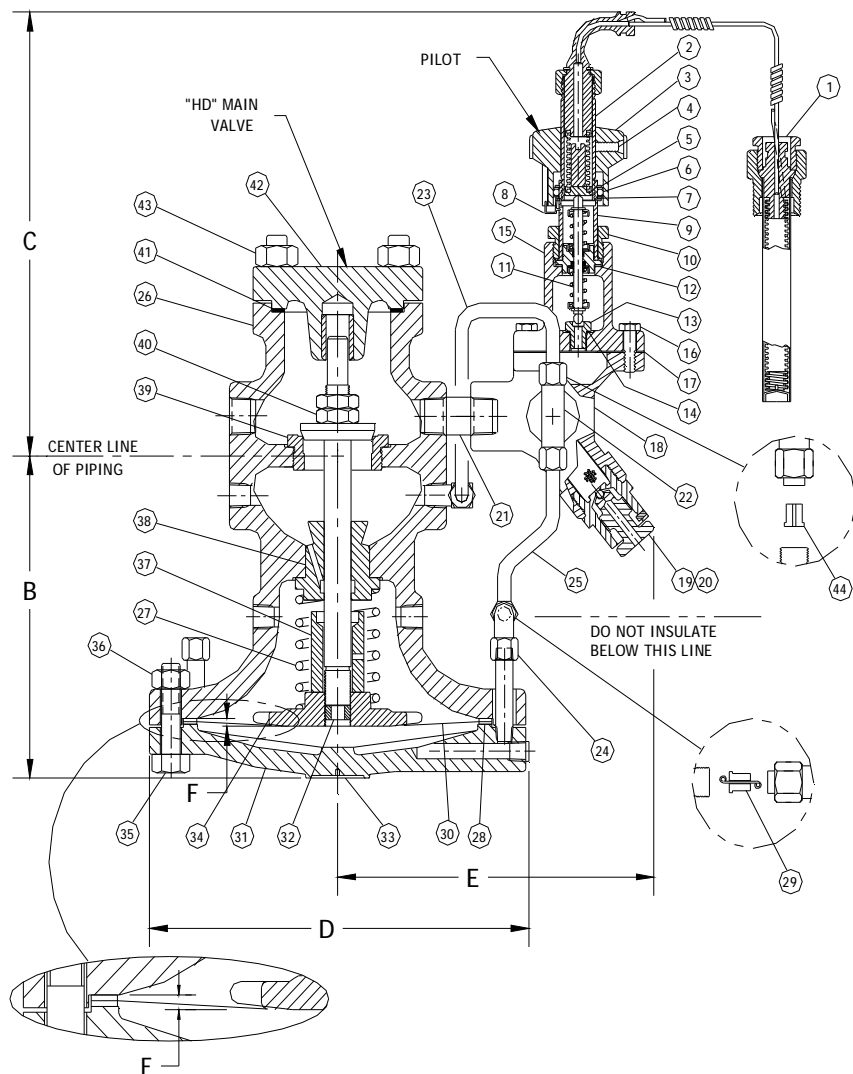

LIST OF MATERIALS

| PILOT: | | |
|------------------|-------------------------|---------------------|
| ITEM | PART NAME | MATERIAL |
| 1 | Thermo System | Specify Temp. Range |
| 2 | Case Tube | Brass |
| 3 | Adjusting Knob | Phenolic |
| 4 | Set Screw | Stn. Stl. |
| 5 | Retaining Ring | Steel |
| 6 | O-Ring | Neoprene |
| 7 | O-Ring Retaining Washer | Brass |
| 8 | Pointer | Stn. Stl. |
| 9 | Body Extension | 304 Stn. Stl. |
| 10 | Lock Nut | B-16 Brass |
| 11 | Head & Guide Assy | Stn. Stl. |
| *12 ¹ | Gasket, Head Guide | Copper |
| 13 | Seat | Stn. Stl. |
| *14 ¹ | Seat Gasket | Stn. Stl. |
| 15 | Body, Pilot | Ductile Iron |
| 16 | Cap Screws | Steel |
| *17 ¹ | Gasket | Non-Asbestos |

| MAIN VALVE: | | |
|------------------|--------------------------------|------------------------|
| ITEM | PART NAME | MATERIAL |
| 18 | Pilot Adaptor | Ductile Iron |
| *19 | Blowdown Valve | Stn. Stl. |
| *20 | Screen, 40 Mesh | Stn. Stl. |
| 21 | Nipple | Black Pipe, Sch.80 |
| 22 | Male Branch Tee | Brass |
| 23 | Tubing, Pilot to Body | Copper Tubing |
| 24 | Elbow, Tube to Pipe | Brass |
| 25 | Tubing, Pilot to Diaph. | Copper Tubing |
| 26 | Main Valve Body | Ductile Iron |
| 27 | Spring | 302 Stn. Stl. |
| *28 | Gasket, Diaph. Cover | Grafoil |
| 29 | Orifice Assy, Diaphragm | Brass (Stn. Stl. Wire) |
| *30 | Diaphragm, Main Valve | Phos. Bronze |
| 31 | Diaphragm Cover | Ductile Iron |
| 32 | Set Screw | Stn. Stl. |
| 33 | Name Plate | Stn. Stl. |
| 34 | Diaphragm Plate | C.I. A126 Cl. B |
| 35 | Cap Screws | Steel |
| 36 | Nuts | Steel |
| 37 ² | Plug Stop | Steel Tubing |
| 38 | Stem Guide Assy | Brass |
| *39 | Seat Ring | 402 Stn. Stl. |
| *40 | Disc & Stem Assy | Stn. Stl. |
| *41 ¹ | Gasket, Cover | Grafoil |
| 42 ³ | Cover Assembly | Ductile Iron |
| 43 | Nuts | Steel |
| 44 | Bleed Orifice, Male Branch Tee | Brass |

Note: The 'D' valve is cast iron instead of ductile iron.

¹ Must use Factory Replacement Parts for these gaskets

² Not used on 1/2, 3/4 & 1" valves

³ Stem not guided in bottom cover on 1/2, 3/4, & 1" valves

*Denotes recommended spare parts

Specify D or HD valve when ordering.

HD Valve Pressure-Temperature Ratings

| | |
|------------------|-----------------|
| Screwed Valves | 450 PSI @ 650°F |
| 150# Flg. Valves | 150 PSI @ 566°F |
| 300# Flg. Valves | 450 PSI @ 650°F |

D Valve Pressure-Temperature Ratings

| | |
|------------------|-----------------|
| Screwed Valves | 250 PSI @ 450°F |
| 125# Flg. Valves | 125 PSI @ 353°F |
| 250# Flg. Valves | 250 PSI @ 450°F |

Pilot Temperature Adjusting Ranges

| | |
|-------------|-------------------|
| Temperature | Identifying Color |
| 60-120°F | Yellow |
| 100-160°F | Black |
| 120-180°F | Blue |
| 160-220°F | Red |
| 200-260°F | Green |

'HDT' DIMENSIONAL DATA CHART

| SIZE | FACE TO FACE | | B | C | D | E | 'HD' F | 'D' F | WEIGHT-LB | |
|-------|--------------|---------|--------|--------|-------|--------|--------|-------|-----------|-----|
| | FLANGED | | | | | | | | NPT | FLG |
| | 150 PSI | 300 PSI | | | | | | | | |
| 1/2 | 4 3/8 | | 5 1/2 | 9 1/4 | 6 1/2 | 6 1/2 | .143 | .156 | 18 | |
| 3/4 | 4 3/8 | | 5 1/2 | 9 1/4 | 6 1/2 | 6 1/2 | .143 | .156 | 18 | |
| 1 | 5 3/8 | 5 1/2 | 6 | 6 1/4 | 9 1/4 | 8 1/4 | .149 | .156 | 23 | 35 |
| 1 1/4 | 6 1/2 | | 7 3/8 | 9 1/4 | 8 3/4 | 7 1/4 | .175 | .125 | 43 | |
| 1 1/2 | 7 1/4 | 6 7/8 | 7 3/8 | 9 1/4 | 8 3/4 | 7 1/4 | .175 | .140 | 43 | 60 |
| 2 | 7 1/2 | 8 1/2 | 9 | 8 1/4 | 9 1/4 | 10 7/8 | .202 | .165 | 65 | 85 |
| 2 1/2 | | 9 3/8 | 10 | 9 | 9 1/4 | 11 3/4 | .209 | .180 | | 105 |
| 3 | | 10 | 10 3/4 | 8 7/8 | 9 1/4 | 13 1/4 | .237 | .230 | | 145 |
| 4 | | 11 7/8 | 12 1/2 | 10 7/8 | 9 1/4 | 14 3/4 | .237 | .292 | | 235 |
| 6 | | 15 1/8 | 16 | 14 1/8 | 9 1/4 | 19 3/4 | .326 | .187 | | 470 |

Each Watson McDaniel Company Product is warranted against defects in material and workmanship for one year from date of shipment. This warranty extends to the first retail purchaser only. All defective material must be returned to the person from whom you purchased the Product, transportation prepaid, free of any liens or encumbrances, and if found to be defective will be repaired free of charge or replaced, at the warrantor's or seller's option. If the material is replaced, any replacement will be invoiced in the usual manner and after inspection of alleged defective material an adjustment will be made for depreciation caused by purchaser's use. In no event will Watson McDaniel Company be liable to do more than refund the original contract price. Incidental and consequential damages are excluded, whether under this warranty or otherwise. All implied warranties, including warranties of merchantability and fitness for a particular purpose, are disclaimed and excluded.

INSTALLATION

1. Piping hookup Fig. 1 is a typical installation to be used as a guide for planning piping.
2. Valve must be installed in horizontal position with flow in direction as indicated by arrow on body. Main valve diaphragm to be in down position. Caution: When installing flanged valves make sure flange bolts are tightened evenly so as not to overstress and crack flanges.
3. Make sure regulator is installed close enough so the capillary will reach the system to be heated. Standard capillary length is eight (8) feet.
4. Piping on downstream side of valve is generally larger than valve to eliminate flow restriction.
5. Line should be blown down thoroughly.
6. By-pass connections of same size as pressure reducing valve is recommended. (See Fig. 1.) Use gate valves before and after pressure reducing valve and globe valve as by-pass valve.
7. Install a separator with a steam trap ahead of the main valve which will remove nearly all the condensate from the steam. This will enhance the operation and service life of both the valve and the equipment downstream.
8. A 'Y' type strainer should be installed before the pressure reducing valve. Make sure sufficient clearance is allowed so strainer screen can be removed.
9. Assemble Pilot to Main Valve:
 - a) Remove protector from pilot adaptor.
 - b) Place gasket on pilot adaptor making sure roll pin in pilot adaptor is inserted thru small hole in gasket (See Service Illustration).
 - c) Assemble pilot to adaptor making sure roll pin in adaptor is inserted in blind hole at the base of the pilot. Tighten bolts evenly.
10. Connect Thermostatic Bulb to System.
 - a) Always avoid sharp bends or any kinks in the flexible capillary. Provide support for the capillary tubing to prevent damage, keeping it away from hot surfaces.
 - b) Install thermostatic bulb in a location that avoids any hot or cold spots in system. Make sure the entire bulb is exposed to the system fluid.
 - c) **IMPORTANT:** When bulb is installed in a thermal well, a heat transfer compound (hi-temp. grease) must be packed into the well to insure a fast transfer of heat from the system to the bulb.
 - d) Install a thermometer (verify accuracy) in the system, as close to the thermostatic bulb as possible, for the purpose of setting the temperature in the system.
 - e) If the temperature scale on the control knob can not be readily seen, it can be adjusted by loosening Lock Nut (10) and rotating the assembly to the desired position.

START UP

1. Make sure all lines have been blown down to remove initial dirt and scale from system.
2. Close all valves in installation.
3. Turn adjusting knob to the desired temperature.
4. Open drain valve at the separator or other upstream drain valve to make sure all condensate is drained from inlet piping. If this is not

done, serious damage to the piping system can occur as a result of water hammer.

5. Slowly open down stream gate valve. Bypass, if installed, should be closed.
6. Open inlet gate valve slowly. Watch for possible water hammer.
7. Allow sufficient time for the system being heated to stabilize, then check system thermometer for the desired temperature. If necessary turn the adjusting knob up or down a few degrees to reach the system requirement. If, after the system has fully stabilized, the adjusting knob reading does not agree close enough with the thermometer, the knob can be re-calibrated by following section 1 of the Service Instructions.
8. Inspect all piping connections and valve for possible leaks and tighten as required. Check and retighten main valve diaphragm bolts.

MAINTENANCE

It is a good practice to periodically inspect and clean the following parts. Frequency of inspection and cleaning are dependent on the condition of the steam system.

1. Blow down or clean all pipe line strainer screens.
2. Inspect and clean pilot screen (20).
3. Inspect and clean bleed and diaphragm orifice.
4. Check all connections for leakage.

Note: These items should also be checked a few days after valve is initially installed and shortly after start-up during each heating season.

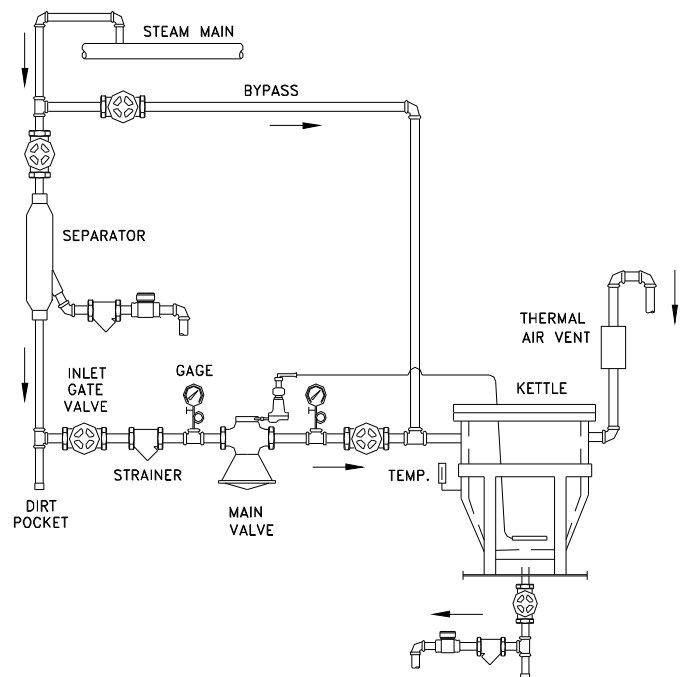

(FIG. 1) TYPICAL INSTALLATION

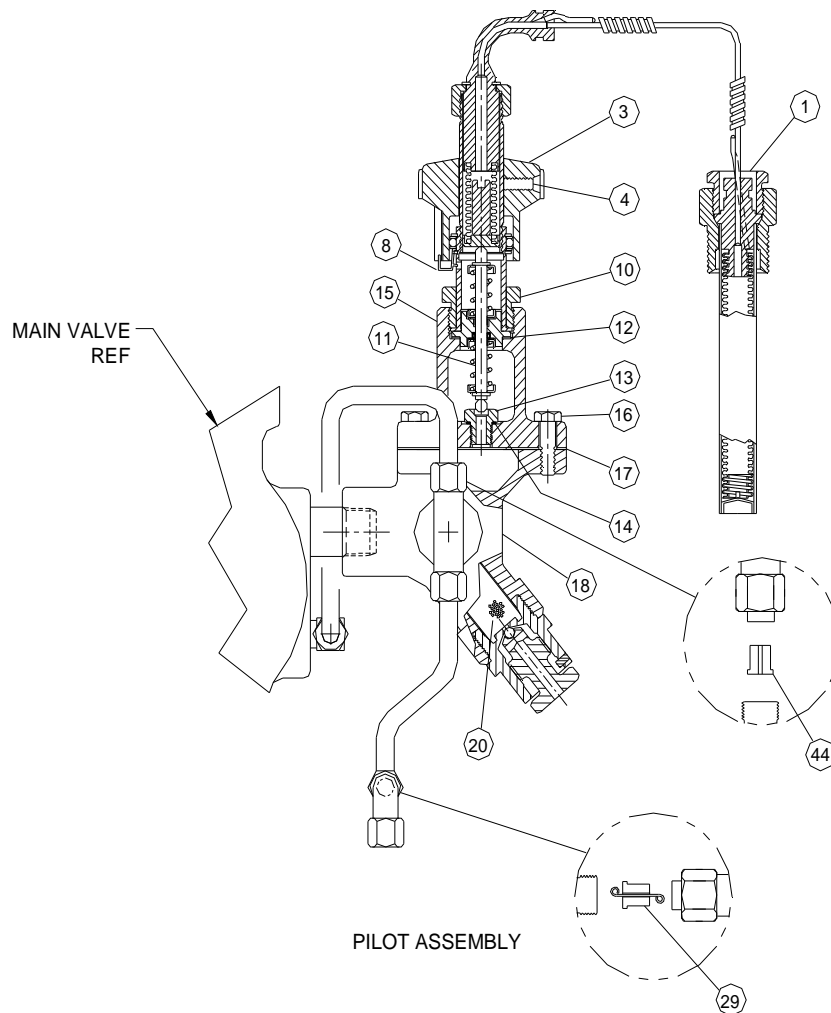

SERVICE INSTRUCTIONS: TEMPERATURE PILOT

- 1) Re-calibrate Temperature Scale on Adjusting Knob (3).
 - a) Make sure the thermostatic bulb (1) is completely immersed in the fluid being heated.
 - b) Slowly turn the adjusting knob clockwise until the main valve closes to stop steam flow.
 - c) Slowly turn the adjusting knob counterclockwise until a slight flow of steam is noticed.
 - d) Use a 3/32" hex wrench to loosen set screw (4) in the adjusting knob, then rotate adjusting knob so the temperature on the scale agrees with the system thermometer. **CAUTION:** Do not change the spacing between the bottom of adjusting knob (3) and the pointer (8). Retighten set screw.

- 2) Servicing Pilot Seat and Disc - Caution: Regulator must be cool before servicing.
 - a) Isolate valve from all sources of pressure making sure there is no back pressure at the outlet.
 - b) The pilot can be serviced while attached to the regulator but for convenience sake it can be removed from the pilot adapter (18).
 - c) Remove Lock Nut (10) and disassemble the temperature adjusting assembly.
 - d) Withdraw the head and guide assembly (11) and inspect the disc and stem seals for wear. If worn, replace complete assembly.
 - e) Remove pilot seat (13) with 1/2" hex socket. Inspect sealing surface and threads for wear. If worn replace seat and new gasket (14).
 - f) Before reassembly, it is recommended that the pilot tubing orifices (29) & (44) and screen (20) be inspected and cleaned at this time.

| SIZE | 'HD' F | 'D' F |
|-------|-----------|----------|
| 1/2 | .143 | .156 |
| 3/4 | .143 | .156 |
| 1 | .149 | .156 |
| 1 1/4 | .175 | .125 |
| 1 1/2 | .175 | .140 |
| 2 | .202 | .165 |
| 2 1/2 | .209 | .180 |
| 3 | .237 | .230 |
| 4 | .237 | .292 |
| 6 | .326 | .187 |

Consult factory for 'F' dimension of 'HD' valves manufactured prior to 6/09.

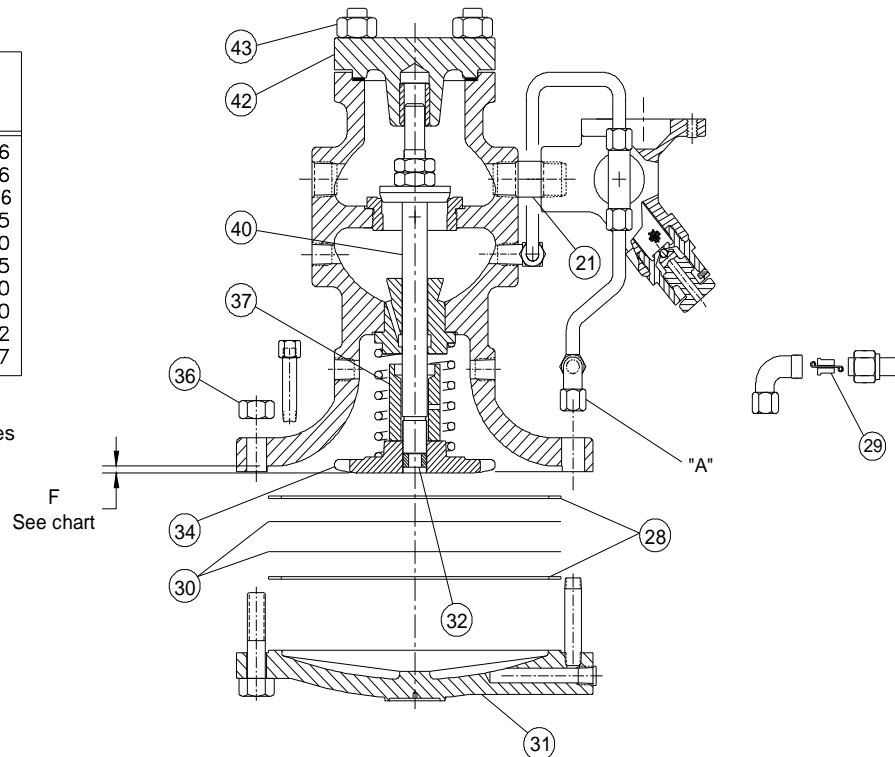

SERVICING INSTRUCTIONS: MAIN VALVE

CAUTION - Regulator & pilot must be cool before disassembly.

1.) Servicing main valve diaphragms (30) .

- Shut off inlet gate valve and make sure downstream pressure is zero. Downstream gate valve could also be shut when pressure is at zero to prevent any downstream condensate from entering the valve.
- Disconnect copper tubing to diaphragm chamber at 'A' check diaphragm orifice (29) for damage, etc. **CAUTION:** Some hot condensate may leak from line and diaphragm chamber.
- Loosen main valve diaphragm nuts (36) . **CAUTION:** Chamber filled with condensate which could be hot. First slightly loosen nuts, then further loosen several nuts on opposite side from where you are standing. Pry cover from valve allowing condensate to drain from valve away from you. Gently pry diaphragm loose from body to drain condensate from body of valve.
- Remove all bolts and diaphragm cover (31) .
- Inspect the two (2) metal diaphragms (30) for small cracks and wrinkles. Replace if necessary.
- Clean diaphragm, diaphragm plate and gasket surfaces before reassembly
- Make sure diaphragm plate (34) is securely fastened to stem with locking set screw. Check diaphragm plate setting. See dimension 'E' above.
- Valve stem assembly (40) can be checked for proper movement by pushing up on diaphragm plate. **CAUTION:** Condensate may be in upper portion of body.
- Replace diaphragm gaskets (28) if necessary. Use only factory replacement gaskets.
- Center diaphragms and gaskets on cover. Bolts will assist in centering.
- Assemble making sure bolts are taken-up evenly. After system is started check bolts again for tightness.

2.) Servicing main valve disc and seat.

- Follow disassembly instructions as noted in diaphragm servicing instructions, a) above.
- Loosen diaphragm plate set screw (32) and remove diaphragm plate (34).
- Remove cover nuts (43) and cover (42) .
- Remove stem and disc assembly from valve and inspect disc and seat for wear. Minor wear can be corrected by lapping disc and seat together with 400 grit lapping compound. Inspect the disc and seat for signs of scale or dirt which could have caused leakage.
- Check for body erosion around seat ring. Check seat ring for possible damage or excessive wear and any signs of scale or dirt which could have caused leakage. Replace if necessary. Replacement seats and discs should be lapped.
- Reassemble as required. Make sure plug stop (37) is installed properly.

TROUBLESHOOTING GUIDE FOR SERIES "HD" & "D" REGULATORS

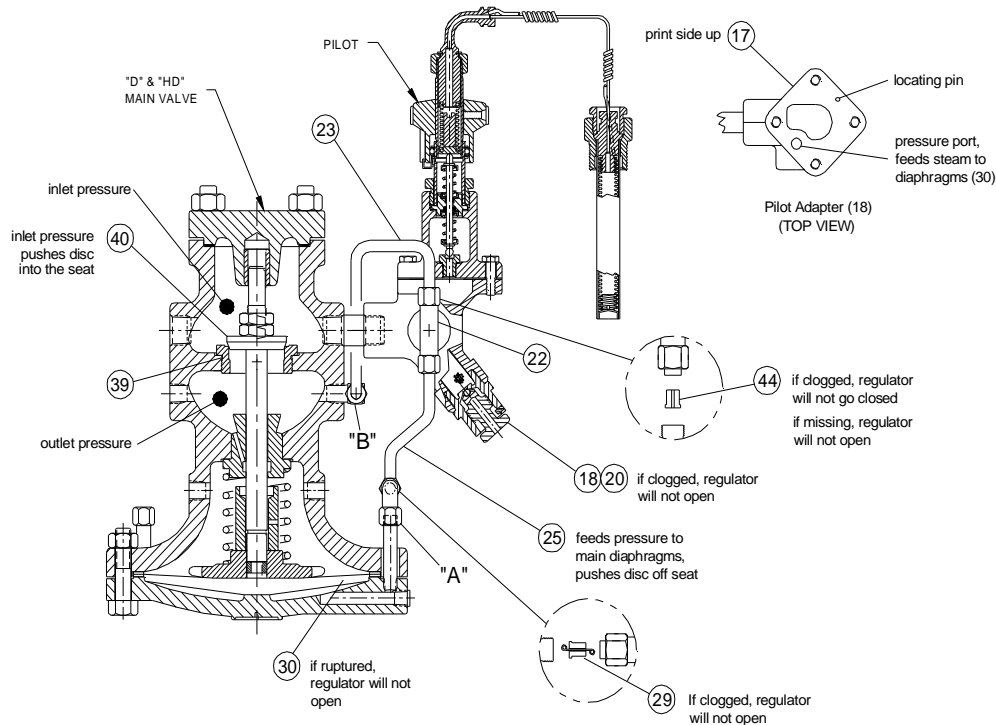

IMPORTANT NOTE:

By far the most common field problem with 'HD' & 'D' valves is that they become saturated with condensate or water. 'HD' & 'D' valves are designed to operate on steam and may perform erratically or fail to operate at all if the valve and/or pilot contain water. You should always make certain all water is drained from the valve and pilot first before trying to troubleshoot a malfunctioning 'HD' & 'D' valve.

REGULATOR WILL NOT COME UP TO PRESSURE OR TEMPERATURE

1. Shut off inlet gate valve to regulator and make sure downstream pressure is zero.
2. Make sure that the Pilot Gasket (17) is properly oriented on the Pilot Adapter (18); otherwise, the pressure port in the adaptor will be blocked and regulator will not open.
3. Check Pilot Strainer (20) for blockage as well as the upstream pipeline strainer.
4. Inspect Diaphragm Orifice (29) for blockage and Diaphragms (30) for rupture.
5. Check that the Bleed Orifice (44) at the Male Branch Tee (22) is not missing.

PRESSURE OR TEMPERATURE OVERRIDES SET POINT: ISOLATE REGULATOR FROM PILOT FOR TESTING

1. Shut off inlet block valve to regulator and make sure downstream pressure is zero.
2. Adjust the pilot to the closed position. If it is a Pressure pilot, back out the adjustment screw until there is

no compression on the spring. If a Temperature pilot, turn the temperature adjusting knob to the lowest setting.

3. Disconnect the pilot tube (25) at the regulator diaphragm which is indicated as point "A" in the illustration above. Also disconnect the smaller pilot tube (23) at the side of the regulator body designated point "B" in the above illustration.
4. Stand clear of the tube connections and open the block valve upstream of the Main Valve only partially to limit the steam pressure to the regulator. Full line pressure is not necessary for this test.
5. Regulator seat test - With the long pilot tube disconnected at point 'A' the regulator should be closed. If there is steam blowing out of the body side connection at point "B", the main valve and seat are leaking and require inspection for debris that is holding the valve off the seat or erosion of the sealing surfaces.
6. Pilot seat test - With the pilot closed there should not be any steam coming out of the long tubing at point "A". If there is steam flow, the pilot is not closing off and must be inspected for debris or seat erosion. Try running the adjustment screw in & out a few times to clear the debris. If that is not successful, the pilot must be cleaned, repaired or replaced.

SYSTEM TROUBLESHOOTING

| PROBLEM | POSSIBLE CAUSE | CORRECTION |
|--|---|---|
| <p>1. System will not come up to required temperature or valve will not open.</p> | <ul style="list-style-type: none"> a) Valve undersized. b) Downstream piping undersized. c) Pilot not adjusted properly. d) Pilot range not correct. e) Thermostatic bulb is in a hot spot. f) Inlet or outlet gate valve partially closed. g) Upstream pipeline strainer blocked. h) Pilot screen clogged. i) Inlet pressure too low causing reduced capacity through valve. j) Diaphragm orifice blocked. k) Bleed orifice installed wrong, eroded or missing. l) Main valve diaphragms failed. m) Main valve flooded with condensate. | <ul style="list-style-type: none"> a) Check capacity of valve against load requirements. b) Check velocity of steam in piping system. c) Readjust to desired temperature. d) Check the range received against range required. e) Relocate the bulb. f) Open valves. g) Clean strainer. h) Clean screen. i) Check with gauge and correct as required. j) Check and clean orifice. Do not remove clean-out wire. k) Inspect and check per illustration. l) Replace diaphragms. m) Drain unit, see section 'D' in service. Check upstream trap. |
| <p>2. Temperature of system overrides set temperature or valve will not close.</p> | <ul style="list-style-type: none"> a) Valve is extremely oversized. b) Bypass valve open. c) Pilot adjustment set too high. d) Thermostatic bulb is in a cold spot. e) Bleed orifice blocked. f) Dirt in pilot seat or stem guide. g) Foreign object lodged between main valve disc and seat. h) Main valve seat thread leaking. | <ul style="list-style-type: none"> a) Check sizing against service conditions. b) Close valve. c) Readjust to desired temperature. d) Relocate the bulb. e) Inspect and clean. f) Inspect and clean. g) Inspect and clean. h) Check seat ring area for erosion. |