

NON-ELECTRIC CONDENSATE PUMPS

PMPM

Pressure Motive Pump

Watson McDaniel reserves the right to change the designs and/or materials of its products without notice.
©2002 Watson McDaniel Company

Revised 7/2002

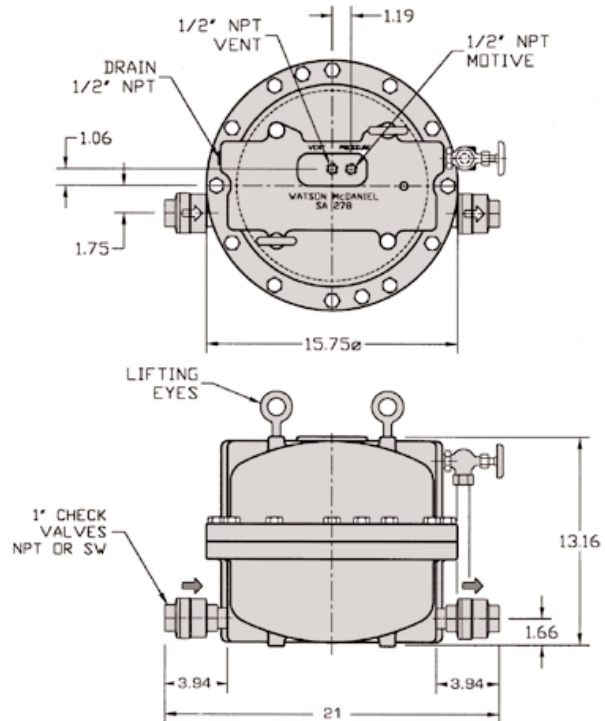
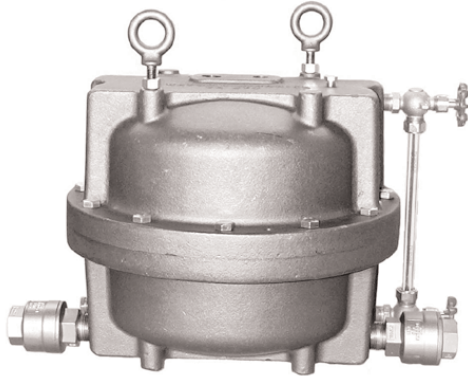

Model	PMPM
Body	Cast Iron
Cover	Cast Iron
Check Valves	Stainless Steel
PMO Max. Operating Pressure	150 PSIG
TMO Max. Operating Temperature	366°F
PMA Max. Allowable Pressure	150 PSIG @ 470°F

TYPICAL APPLICATIONS

The Model **PMPM** pressure motive pump has an **extremely low-profile**. These low-profile tanks are required when draining condensate from process equipment positioned close to the ground which limits the filling head of the pump.

FEATURES

- **Non-Electric** – can be used in remote locations or **NEMA 4, 7, 9 & hazardous areas**
- **Operate using steam, air, nitrogen or other pressurized gases as the motive force**
- **All stainless steel internal mechanism for better corrosion resistance**
- **Wear items on mechanism made from heat-treated stainless steel for extended service**
- **Low-overall height**
- **Dual compression springs made from Inconel-X-750 for high-temperature corrosive service**

MATERIALS

Body & Cover	Cast Iron
Cover Gasket	Garlock
Cover Bolts	Steel
Inlet Valve	Hardened Stainless Steel 40 Rc
Vent Valve	Hardened Stainless Steel 40 Rc
Mechanism Yoke	304 Stainless Steel
Ball Float	304 Stainless Steel
Check Valves	Stainless Steel
Springs	Inconel-X-750
Other Internal Comp	Stainless Steel

NON-ELECTRIC CONDENSATE PUMPS

PMPM

Pressure Motive Pump

Problem

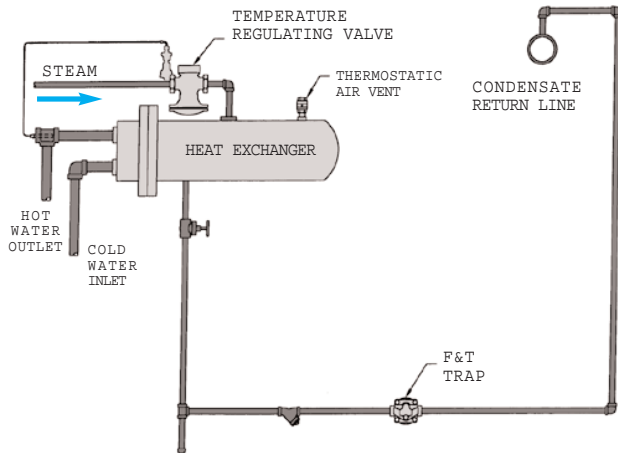

PROBLEM

STALL CONDITION WITH MODULATED STEAM FLOW.

Steam flowing into the heat exchanger is controlled by the temperature regulating valve. When the temperature regulating valve is fully open, any condensate forming inside the heat exchangers will be pushed through the steam trap into the condensate return line. When the temperature regulating valve partially or fully closes the steam pressure inside the heat exchanger can no longer overcome the back pressure against the outlet of the trap and the condensate will build up in the heat exchanger. This condition is called system stall and results in water hammer and poor heat transfer due to the condensate build-up in the heat exchanger.

Solution

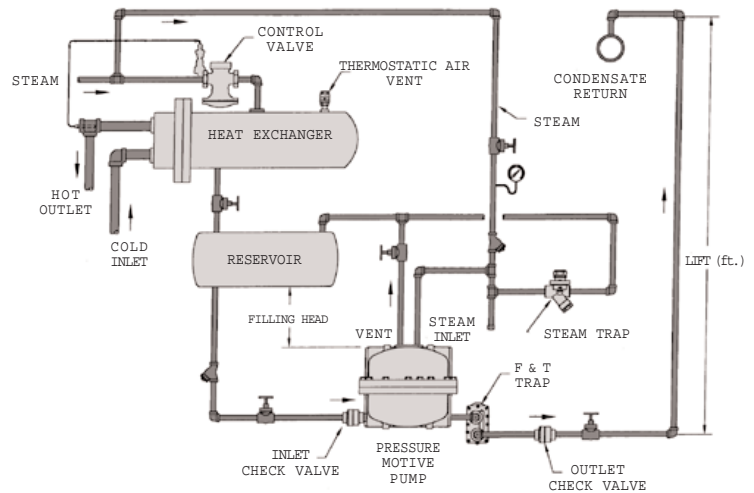

SOLUTION

USE A PRESSURE MOTIVE PUMP AS SHOWN.

When the temperature regulating valve is fully open, any condensate forming inside the heat exchangers will be pushed through the pump and steam trap into condensate return line. When the temperature regulating valve closes, any condensate forming inside the heat exchanger will drain by gravity into the pump tank. When the level inside the pump tank reaches the trip point, high pressure steam will drive the condensate from the tank into the condensate return line. **Note:** A larger steam trap must be used to handle pump discharge.

CAPACITIES – Condensate (lbs/hr)

Motive Pressure (PSIG)	Back Pressure (PSIG)	6" Filling Head	
		Steam Motive	Air Motive
25	15	1200	1720
25	5	1970	2265
50	40	1200	1640
50	25	1480	1980
50	15	1860	2220
50	5	2240	2485
75	60	1160	1935
75	40	1640	2185
75	25	1960	2340
100	60	1415	2020
100	40	1825	2280
100	25	1985	2420
100	15	2175	2455
150	100	1120	1456
150	80	1220	1525
150	60	1570	1885

SIZING

The capacity of the **PMPM** is based on the inlet steam pressure, the system back pressure, and the amount of filling head available. The trap used in a pump trap combination must be sized to handle the instantaneous discharge of the pump. Choose a F&T trap that will pass the condensate load at a 1/4 PSI differential pressure. The PMO of the steam trap must be higher than the motive inlet steam pressure. Consult factory for proper choice of steam trap.

HOW TO ORDER

- Specify:
- Model – **PMPM**
 - For pump/trap combination – to properly size the steam trap, specify condensate load (lbs/hr) and inlet motive pressure for the pump