

BACK PRESSURE RELIEF VALVES

R Series

Relief and Back Pressure

Watson McDaniel reserves the right to change the designs and/or materials of its products without notice.
©2006 Watson McDaniel Company

Model	R Series / *10691 Series
Service	Liquids
Sizes	1/2", 3/4", 1", 1 1/4", 1 1/2", 2", 3"
Connections	NPT
Body & Seat Material	Bronze
Valve Material	1/2" – 1 1/2" Stainless Steel 2" – 3" Bronze
Model 10691	*1/2", 3/4", 1" EPDM (tight shut-off)
Max. Inlet Pressure	300 PSIG

* For tight shut-off use 10691 with EPDM soft seat. Available in 1/2", 3/4", 1" only.

DESIGN PRESSURE/TEMPERATURE RATING – PMA/TMA

NPT 300 PSIG @ 180° F

PRESSURE-ADJUSTING SPRING RANGES

Relief Pressure (PSIG)	Spring No. – Color
1-6	4, yellow (1/2" – 1 1/2" only)
5-35	3, silver
25-100	2, blue
75-300	1, red

TYPICAL APPLICATIONS

The R Series & 10691 Series Back Pressure Relief Valves are used in the following applications:

Water pump bypass for Irrigation, sprinkler systems on golf courses, fountains, and fire protection systems

Fuel oil pump bypass on commercial systems or large residential systems

Caution: Not to be used as an emergency or safety relief valve.

FEATURES & OPTIONS

- Four Springs – easily interchanged to cover pressures from 1 to 300 PSIG
- Heavy-duty bronze valve body
- 10691 Series has EPDM Seat for tight shut-off (1/2" - 1")

PRESSURE ADJUSTMENT

To adjust set pressure of valve, remove top cap, loosen lock nut and adjust pressure with steel setting screw. Rotating the screw clockwise increases the compression on the spring thereby increasing the set pressure. Rotating the screw counter-clockwise lowers the set pressure. Tighten the lock nut and replace top cap and gasket when desired set pressure is reached.

HOW TO ORDER

Specify: • Regulator R Series
• Size based on capacity chart
• Spring range or relief pressure

Example: 1" R Series – 5 - 35 lbs. Relief pressure range
1" R Series – 20 lbs. (factory set)



Series 10691 Model Relief Valve has Soft EPDM Seat for tight shut-off in sizes 1/2", 3/4", 1"

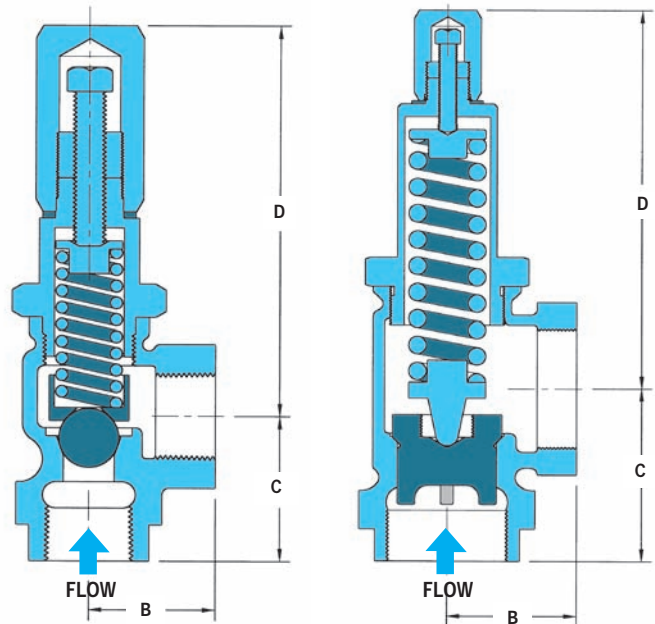

1/2" through 1 1/2"

2" & 3"

DIMENSIONS & WEIGHTS – inches /pounds

Size	B	C	D	Weight (lbs)
1/2"	1 1/8	1 1/2	3 5/8	1.5
3/4"	1 3/8	1 3/4	5 1/2	2
1"	1 5/8	2 1/4	6	3
1 1/4"	1 7/8	2 3/8	6	6
1 1/2"	2 3/16	2 5/8	6 7/8	8
2"	2 1/2	2 5/16	8 3/4	10
3"	3 7/8	4 1/8	10 7/8	25

BACK PRESSURE RELIEF VALVES

R Series

Relief and Back Pressure

CAPACITIES – Water (gpm)

At 10% Over Set Pressure								
Spring Range	Set Pressure (PSIG)	1/2"	3/4"	1"	1 1/4"	1 1/2"	2"	3"
1-6	3	1.2	2.2	3.2	4.3	5.4		
5-35	10	0.3	0.4	0.4	0.5	0.5	0.6	0.7
5-35	20	0.6	0.7	0.8	1.0	1.1	1.3	1.6
25-100	50	1.0	1.3	1.6	1.8	2.2	2.6	5.0
25-100	75	1.4	1.9	2.3	2.8	3.4	4.0	5.0
75-300	100	1.9	2.5	3.2	3.8	4.6	5.4	6.9
75-300	200	3.4	4.4	5.8	6.9	8.2	9.7	12.3

At 20% Over Set Pressure								
Spring Range	Set Pressure (PSIG)	1/2"	3/4"	1"	1 1/4"	1 1/2"	2"	3"
1-6	3	2.2	3.4	4.6	5.8	7.1		
5-35	10	0.6	0.8	1.1	1.3	1.4	1.8	2.2
5-35	20	1.4	1.9	2.4	3.0	3.4	4.1	4.8
25-100	50	1.8	2.0	3.1	3.8	4.4	5.4	6.4
25-100	75	2.3	3.2	4.0	4.8	5.6	6.9	8.1
75-300	100	3.6	4.2	5.0	6.3	7.0	7.3	8.9
75-300	200	6.5	7.6	9.0	11.2	12.4	13.1	16.0

The R Series Relief Valve water capacities at both 10% and 20% over "Set Pressure" are tabulated in the above table. Enter the chart at the desired "Set Pressure" in the left-hand column and read the capacity in GPM to determine proper Valve Size. Select a spring with a relief range that includes the "Set Pressure" required. Example: A 1" valve set at 50 PSIG will pass 3.1 GPM if the system pressure exceeds the set point by 20%.

HOW IT WORKS

The Relief Valve is actuated by the system pressure on the inlet side of the valve. Valve loading is provided by a spring. The adjustment is done by removing the cap and rotating the screw clockwise or counter-clockwise.

Spring load tends to close the main valve against the opening force of the upstream (or relief) pressure. Valve will be open at the slightest increase in pressure above the spring set point, and closes when the excess pressure has been relieved.

The higher the system pressure is above the relief set point pressure, the more flow the valve will pass. It is therefore typical to specify the maximum capacity of a back pressure relief valve at 10% & 20% over set pressure.

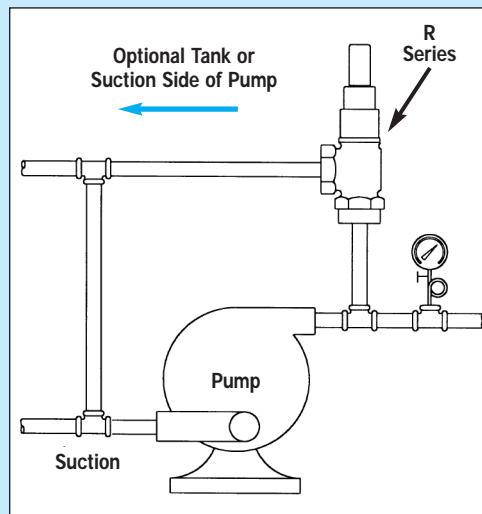

A Relief Valve allows water to recirculate through the pump even when the discharge valve on the pump is completely closed. As a rule a minimum of 20% of the pump capacity must recirculate to stop overheating of the pumped liquid.

