

# LIQUID DRAINERS

## WLD1800/1800R

### Guided Float Type Liquid Drain Trap

Watson McDaniel reserves the right to change the designs and/or materials of its products without notice.  
©2002 Watson McDaniel Company

Revised 4/2003

Model	WLD1800, WLD1800R
Sizes	1/2", 3/4"
Connections	NPT
Body Material	Stainless Steel
PMO Max. Operating Pressure	400 PSIG
Pressure/Temperature Rating	400 PSIG @ 500° F



WLD1800  
(Non-Repairable)



WLD1800R  
(Repairable)

### TYPICAL APPLICATION

The **WLD1800** is used on industrial air and gas applications for drainage of liquid from systems.

### HOW IT WORKS

This liquid drainer has a float-operated valve that gives the trap a modulating flow characteristic. The amount of liquid flowing into the drainer is sensed by the float which positions the main valve to discharge the liquid at the same rate as it is received.

### FEATURES

- Stainless steel body
- All stainless steel internals for longer service life
- Guided float ensures proper valve seating on every cycle
- Repairable unit available (WLD1800R model)

### SAMPLE SPECIFICATION

The liquid drain trap shall have a guided-float operation with a tamper proof seal welded stainless steel body and all stainless steel internals. The unit shall be available with an in-line repairable version. All units to be equipped with FNPT threaded end connections.

### INSTALLATION

The installation should include isolation valves to facilitate maintenance and an in-line strainer. The trap must be level and upright for the float mechanism to operate. Trap must be sized and properly located in the system.

### MAINTENANCE

Close isolation valves prior to any maintenance. The WLD1800 is a disposable unit, but with the WLD1800R all working components can be replaced. Repair kits include float, lever & seat assembly and gaskets. For full maintenance details see Installation and Maintenance Manual.

### MATERIALS

Body	Stainless Steel, AISI 304
Inlet & Outlet Fittings	Stainless Steel, AISI 304
Float Assembly	Stainless Steel, AISI 304
Valve & Lever Assembly	Stainless Steel, AISI 303
Seat	Hardened Stainless Steel
Gasket & Washer (seat)	Garlock
Bolt, Hex, HD	Stainless Steel, AISI 316
Nut, Jam	Stainless Steel, 18-8

### HOW TO ORDER

Refer to the capacity chart to determine which model is required to satisfy the condensate load. Specify model, orifice and pipe size that meets the load requirement.

# LIQUID DRAINERS

## WLD1800/1800R

Guided Float Type Liquid Drain Trap

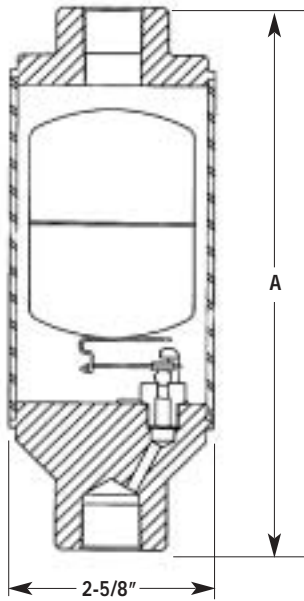

**WLD1800**  
(Non-Repairable)

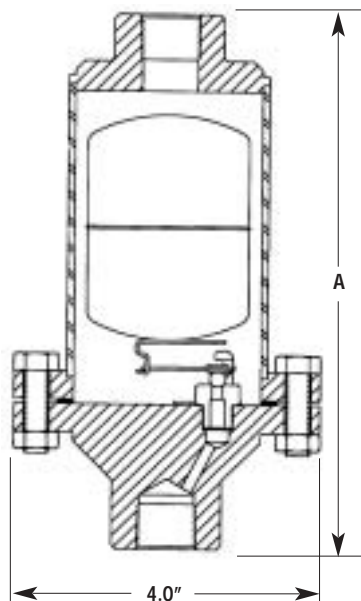

**WLD1800R**  
(Repairable)

DIMENSIONS – inches / pounds			
Model	Size (Inlet x Outlet)	A	Weight (lbs)
WLD1801	3/4" x 1/2"	7	4
WLD1801R	3/4" x 1/2"	7-3/8	4
WLD1802	3/4" x 3/4"	7	4
WLD1802R	3/4" x 3/4"	7-3/8	4
WLD1803	1/2" x 1/2"	7	4
WLD1803R	1/2" x 1/2"	7-3/8	4

COLD WATER CAPACITIES – (lbs/hr)																		
Model	Orifice	Differential Pressure (PSI)																
		1	2	5	10	15	20	30	50	100	150	175	200	250	275	300	350	400
WLD1800 SERIES	.078	60	80	120	130	180	260	315	400	570	700	750	800	900	940	1050	1050	1120
	#38	90	120	175	195	275	385	470	610	860	1050	1125	1200	1350	1425			
	.125	160	230	325	365	510	730	790	1150	1630	2000	2150						

CAPACITY CORRECTION FACTORS																	
Specific Gravity	1	.98	.96	.94	.92	.90	.88	.86	.84	.82	.80	.75	.70	.65	.60	.55	.50
Correction Factor	1	.99	.98	.97	.959	.949	.938	.927	.917	.906	.894	.866	.837	.806	.775	.742	.707

Note: To obtain capacity with a liquid other than water multiply water capacity by correction factor.