

PILOTS

"T" Pilot

Temperature Pilot for D & HD Regulating Valves

Watson McDaniel reserves the right to change the designs and/or materials of its products without notice.
©2002 Watson McDaniel Company

Revised 7/2002

Temperature Pilot

- Temperature Control Range: 60° -260°F



TYPICAL APPLICATIONS

The D-Series and HD-Series Regulators used with the "T" Temperature Pilot are used for controlling temperature in various processes and systems. Some examples are:

- Oil heaters
- Process heaters
- Driers
- Ovens
- Vats
- Jacketed Kettles

FEATURES

- Temperature adjustment is made simple and easy by rotating an adjustment knob to the desired temperature setting
- Thermostatic sensing bulb comes with an 8-ft. or 15-ft. length capillary
- Capillary is armored to protect and resist damage
- Overheat protection bellows is incorporated into sensing bulb. 200°F overheat protection up to 350°F
- For steam supply pressure 12 psig or under, our low pressure temperature pilot must be used
- Full port strainer and blow-down valve on pilot adapter to eliminate failure caused by contaminated steam systems

OPTIONS

- Temperature Pilot can be combined with Pressure and Solenoid pilots
- Additional lengths can be ordered in 5-ft. increments; up to 25-ft. maximum length
- Wells are available in 316 stainless steel or brass
- Longer wells can be supplied
- 316 Stainless Steel Sensing Bulb
- Other options available; consult Factory

Note: Watson McDaniel's Low Pressure Temperature Pilot must be used for steam supply pressure less than 12 PSIG

TEMPERATURE-ADJUSTING RANGES

Temperature	Identifying Colors
60 - 120°F (16 - 49°C)	yellow
100 - 160°F (38 - 71°C)	black
120 - 180°F (49 - 82°C)	blue
160 - 220°F (71 - 104°C)	red
200 - 260°F (93 - 127°C)	green

* Other ranges available; consult Factory.

MATERIALS

	Ductile Iron
Body	Ductile Iron
Head & Guide Assembly	Stainless Steel
Seat	Stainless Steel
Sensing Bulb:	
T	Copper
TU	Brass with Union Nut
TUBW	Copper/Brass Well
TUSW	Copper/Stainless Steel Well
TBW	Copper/Brass Well with Gromet
TSW	Copper/Stainless Steel Well with Gromet

"PT"
Pressure & Temperatur
Pilot
(optional)



"T" Pilot

Temperature Pilot for D & HD Regulating Valves

SENSING BULBS AVAILABLE

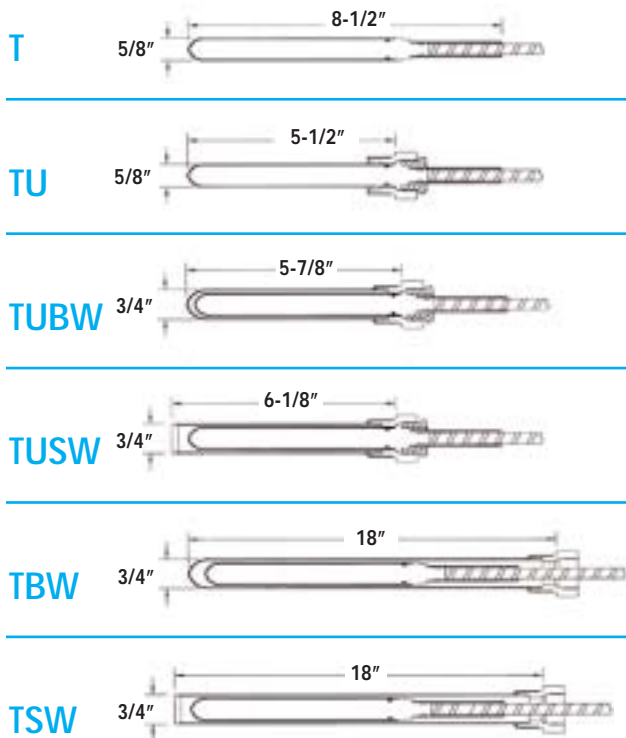

All Union Connections are 3/4" NPT

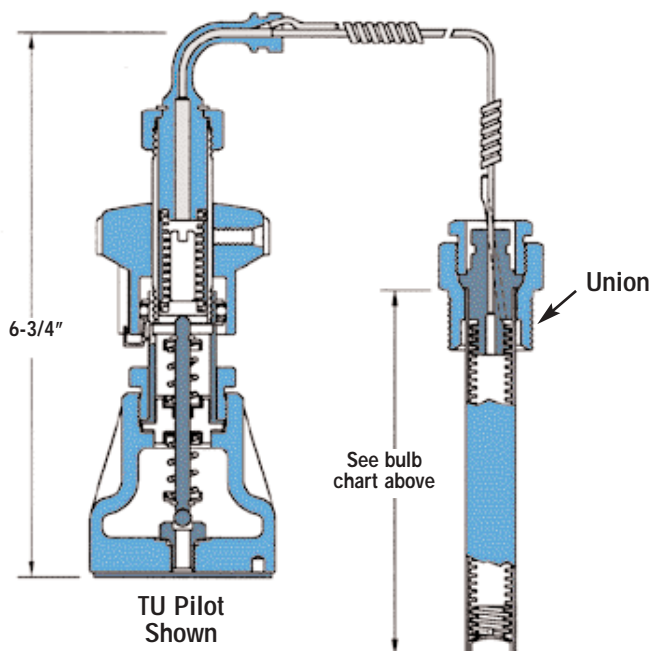

T	Plain copper bulb
TU	Union connected copper bulb that can be screwed into the side of tank
TUBW	Type TU bulb with a brass well. The well can be placed in the side of a tank allowing the sensing bulb to be removed without having to drain the tank of liquid
TUSW	Type TU bulb with a corrosion resistant stainless steel well. The well allows the sensing bulb to be removed from tank without draining the liquid.
TBW	Type T bulb with an extended length brass well. The extended well allows deeper insertion of sensing bulb into tanks.
TSW	Type T bulb with extended stainless steel well. The extended well allows deeper insertion of sensing bulb into tanks.

Other options available; consult factory.

HOW TO ORDER

"T" TEMPERATURE PILOT

Specify:

- Temperature range from the chart or indicate the temperature of the process you wish to control.
- The length of capillary required. 8-ft. is standard.
- Bulb type needed:
T, TU, TUBW, TUSW, TBW & TSW.

REGULATOR BODY

Specify:

- **D** or **HD** regulator body.
- Regulator size or capacity of steam required.
- End connections
(threaded, 125/150/250/300# flanged).

RECOMMENDED PRESSURE

Minimum Inlet Pressure: 5 psig*