

SPECIALTY PRODUCTS

WVBSS

Stainless Steel Vacuum Breaker

Watson McDaniel reserves the right to change the designs and/or materials of its products without notice.
©2002 Watson McDaniel Company

Revised 7/2002

Model	WVBSS
Sizes	1/2"
Connections	NPT
Body Material	Stainless Steel
PMO Max. Operating Pressure	300 PSIG
TMO Max. Operating Temperature	752°F
PMA Max. Allowable Pressure	300 PSIG up to 752°F
TMA Max. Allowable Temperature	752°F @ 300 PSIG



TYPICAL APPLICATION

The **WVBSS** Vacuum breaker is used with heat exchangers, air coils, jacketed kettles, pressing machines, boiler feed water tanks, sparge systems, liquid process lines, and chilled water lines.

HOW IT WORKS

The breaker introduces air to steam and liquid systems where a vacuum condition exists. Breaking vacuum conditions is necessary to allow for the proper drainage of process systems.

FEATURES

- All stainless steel construction
- Small & compact

SAMPLE SPECIFICATION

Vacuum Breakers shall be of all stainless steel construction with a hardened stainless steel ball valve design.

INSTALLATION

Unit must be installed in a vertical position at the highest point on the heat exchange process.

MAINTENANCE

Dirt is the most common cause of premature failure; therefore, the vacuum breaker should be periodically inspected and cleaned. For full maintenance details, see the Installation and Maintenance Manual.

MATERIALS

Body	Stainless Steel, Series 300
Valve Ball	Stainless Steel, Series 300
Nameplate	Stainless Steel, Series 300

DIMENSIONS

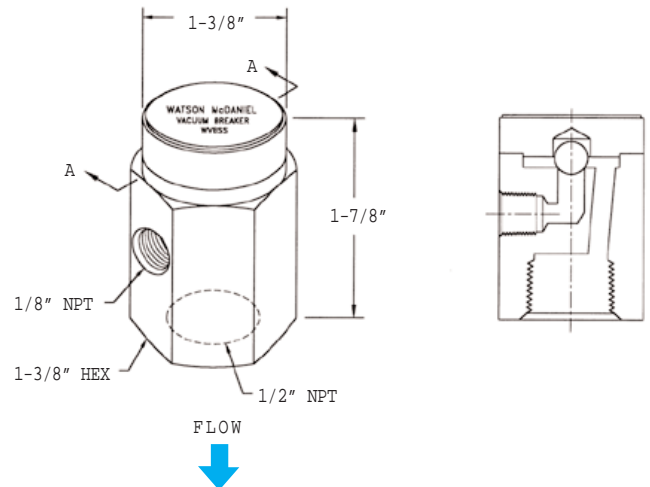

AIR CAPACITIES – (scfm)

Size	in Hg Vacuum					
	2	4	6	8	10	12
1/2"	2.4	3.4	4.0	4.3	4.7	4.9