

STEAM TRAPS

WT1000

Thermostatic Steam Trap

Watson McDaniel reserves the right to change the designs and/or materials of its products without notice.
©2002 Watson McDaniel Company

Revised 7/2002

Model	WT1000
Sizes	1/2", 3/4"
Connections	NPT
Body Material	Stainless Steel
PMO Max. Operating Pressure	300 PSIG
TMO Max. Operating Temperature	Saturated Steam Temperature
PMA Max. Allowable Pressure	1032 PSIG @ 100°F
TMA Max. Allowable Temperature	750°F @ 800 PSIG



TYPICAL APPLICATIONS

DRIP, TRACER: The **WT1000** thermostatic steam trap was specifically designed for drip and tracing applications as well as an air vent for heat exchangers. Like all thermostatic traps the WT1000 is small in size, light in weight, and has excellent air handling capabilities. The discharging of air on start up allows steam to enter the system more quickly.

HOW IT WORKS

The thermostatic trap contains a welded stainless steel thermal element that expands when heated and contracts when cooled. When air and condensate are present the trap is in the open discharge position. When steam reaches the trap the element expands and closes off tightly.

FEATURES

- Excellent air handling capability which allows steam to enter and the system to warm up faster. Extremely important during start up
- Welded stainless steel thermal element which resists shock from water hammer
- Freezeproof when trap is installed in a vertical orientation allowing for complete condensate drainage
- Body is produced from solid stainless steel barstock

SAMPLE SPECIFICATION

The steam trap shall be of thermostatic type with stainless steel body and stainless steel thermal element.

INSTALLATION & MAINTENANCE

Trap can be installed in any position. Steam trap is non-repairable. If new trap is needed, remove from line and replace.

MATERIALS

Trap Housing	Stainless Steel, AISI 304L
Thermal Element	Stainless Steel, 300 Series
Valve	Stainless Steel, AISI 440C

HOW TO ORDER

Specify model and pipe size.

Example:

1/2" WT1000 1/2" pipe connections

DIMENSIONS – inches

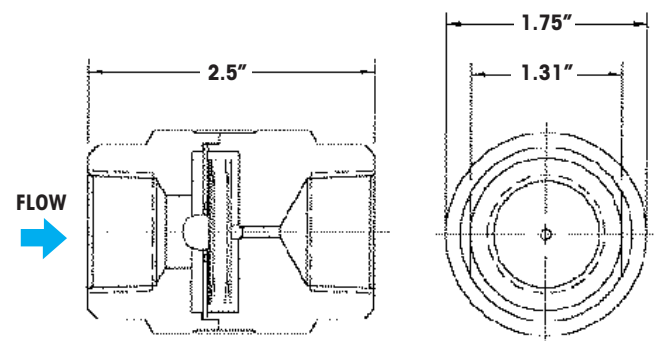

CAPACITIES – Condensate (lbs/hr)

Size	Steam Inlet Pressure (PSI)									
	5	10	20	50	100	125	150	200	250	300
1/2", 3/4"	95	140	195	305	435	485	530	610	685	750

Back Pressure as Percentage of Inlet Pressure	10	20	25	30	40	50	60	70	80	90
Percentage of Reduced Trap Capacity	0	0	0	2	5	12	20	30	40	55