

# STEAM TRAPS

## WT2000C/2100C

### Thermostatic Steam Trap

Watson McDaniel reserves the right to change the designs and/or materials of its products without notice.  
©2002 Watson McDaniel Company

Revised 7/2002

Model	WT2000C	WT2100C
Sizes	1/2", 3/4"	1/2", 3/4"
Connections	NPT	NPT
Body Material	Stainless Steel	Stainless Steel
PMO Max. Operating Pressure	300 PSIG	650 PSIG
TMO Max. Operating Temperature	Saturated Steam Temp.	Saturated Steam Temp.
PMA Max. Allowable Pressure	1032 PSIG @ 100°F	1032 PSIG @ 100°F
TMA Max. Allowable Temperature	750°F @ 800 PSIG	750°F @ 800 PSIG



### TYPICAL APPLICATIONS

**DRIP, TRACER, PROCESS:** The **WT2000C** and **WT2100C** thermostatic steam traps are used for drip, tracing, and process applications. Their compact size, all stainless steel construction, excellent air handling capabilities, and the ability to operate over a wide pressure range make them a good choice for most applications. They can also be used as an air vent on heat exchangers. Thermostatic traps are far superior to bucket traps and thermodynamic traps in their ability to remove air from the system. The discharging of air on start up allows steam to enter the system more quickly.

### HOW IT WORKS

The thermostatic trap contains a welded stainless steel thermal element that expands when heated and contracts when cooled. When air and condensate are present the trap is in the open discharge position. When steam reaches the trap the element expands and closes off tightly.

### FEATURES

- **Thermostatic traps have excellent air handling capability allowing air to be discharged rapidly and steam to enter the system quickly during start up**
- **Integral strainer to protect trap from contamination**
- **Welded stainless steel thermal element which resists shock from water hammer**
- **Freeze proof when trap is installed in a vertical orientation allowing for complete condensate drainage**
- **Body is produced from stainless steel investment casting**
- **Hardened stainless steel seat for extended service life**
- **Will operate at steam pressures up to 650 psig**

### SAMPLE SPECIFICATION

Steam trap shall be of thermostatic type with stainless steel body, thermal element and internal screen.

### INSTALLATION

Isolation valves should be installed with trap. Trap can be installed in any position.

### MAINTENANCE

Steam trap is non-repairable. If failure or malfunction occurs, remove and replace.

### MATERIALS

Trap Housing	Stainless Steel, ASTM A351-CF3
Thermal Element	Stainless Steel
Valve & Seat	Stainless Steel, AISI 416
Strainer Screen	Stainless Steel

# WT2000C/2100C

## Thermostatic Steam Trap

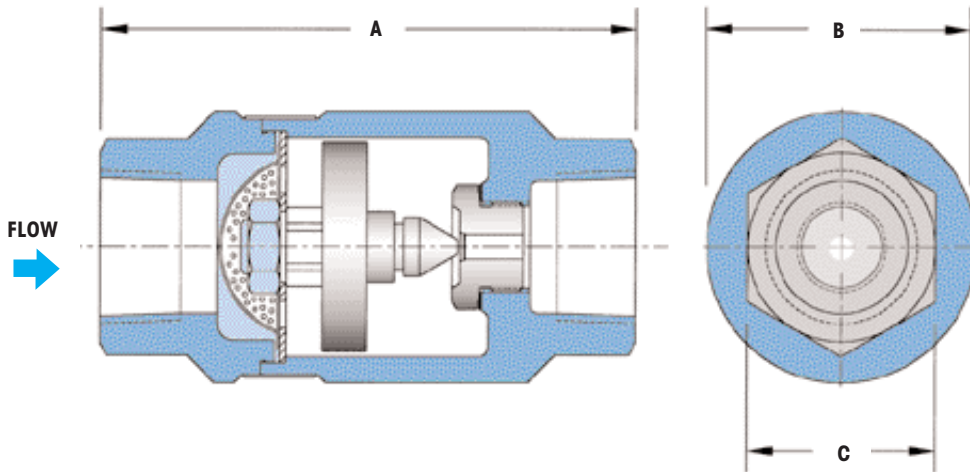

DIMENSIONS & WEIGHTS – inches/pounds				
Size	A	B	C	Weight (lbs)
1/2", 3/4"	3.75	1.88	1.31	1.5

### HOW TO ORDER

Specify model, pipe size and orifice size. If orifice size is not specified, the standard 5/16" diameter will be used.

Example:

- 1/2" WT2000C 5/16" Orifice 1/2" pipe connections with 5/16" orifice
- 1/2" WT2100C 3/16" Orifice 1/2" pipe connections with 3/16" orifice

### CAPACITIES – Condensate (lbs/hr)

Model	Orifice Size	Steam Inlet Pressure (PSIG)															
		5	10	20	50	100	125	150	200	250	300	350	400	450	500	600	650
WT2000C	3/16"	441	625	882	1391	1827	1969	2095	2305	2483	2636						
WT2000C	5/16"	903	1271	1811	2861	3754	4043	4300	4730	5093	5413						
WT2100C	3/16"	441	625	882	1391	1827	1969	2095	2305	2483	2636	2777	2903	3019	3129	3323	3413
WT2100C	5/16"	903	1271	1811	2861	3754	4043	4300	4730	5093	5413	5702	5959	6195	6421	6820	7004

Back Pressure as Percentage of Inlet Pressure	10	20	25	30	40	50	60	70	80	90
Percent Decrease in Trap Capacity	0	0	0	2	5	12	20	30	40	55

**Notes:** 5/16" orifice size is standard and is normally used on process equipment.  
3/16" orifice size is offered for reduced capacity and normally used for tracing applications.