



428 Jones Boulevard Phone: (610)495-5131
Limerick Airport Business Center Fax: (610)495-5134
Pottstown, PA 19464 www.watsonmcdaniel.com

SERIES WT3000/4000

THERMOSTATIC STEAM TRAP

INSTALLATION INSTRUCTIONS

INSTRUCTION PART NO. 1528401

REVISION 1

INSTALLATION

- Before installing the trap, blow out piping thoroughly to remove loose scale and dirt. Use pipe dope or teflon tape sparingly when attaching the trap to the pipe. Observe the pressure limitation shown on the trap label.
- Install the trap below the equipment being drained in a location easily accessible for maintenance and inspection. Be certain that the flow arrow on the trap points in the proper direction.
- Install a dirt pocket to keep dirt away from the trap.
- Discharge piping should be amply sized to avoid excessive back pressures.
- To provide for easy maintenance and service, install a block valve on each side of the trap and install a strainer ahead of the inlet connection.
- All valves should be full ported to achieve the rated capacity of the trap.
- If the discharge piping is to be elevated, be certain that the available differential pressure is adequate to permit proper drainage. Remember, two feet of lift equals approx. one psi.

MAINTENANCE

- Isolate trap from both supply and return line pressures.
- Remove cover and discard gasket.
- Remove thermal element, inspect seating area of valve and seat. If worn, install new repair kit. If dirty, clean with fine emery cloth of 100 grain or finer.
- Reinstall thermal element and new cover gasket. Part No. 15301 for WT3000 & 15330 for WT4000.
- Install cover, use anti-seize compound on and torque: 20-25 ft-lbs for WT3000 & 35-40 ft-lbs for WT4000.

TROUBLE SHOOTING

PROBLEM

1) Trap does not discharge.

2) Trap does not close.

CAUSE

a) Isolation valve closed.
b) Strainer or trap is blocked.

a) Dirt lodged on seat area.

b) Damaged thermostat.

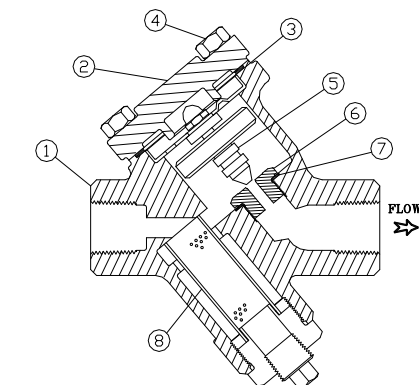

MATERIALS

- Body Stainless Steel, ASTM A351-CF8M
- Cover Stainless Steel ASTM A351-CF8M
- Cover Gasket ... Stainless Steel, AISI 316
- Cover Bolts Steel, ASTM A193 GRB7
- Thermal Element Stainless Steel
- Seat Hardened Stainless Steel, AISI 416
- Seat Gasket ... Stainless Steel, AISI 316
- Strainer Screen Stainless Steel, AISI 304

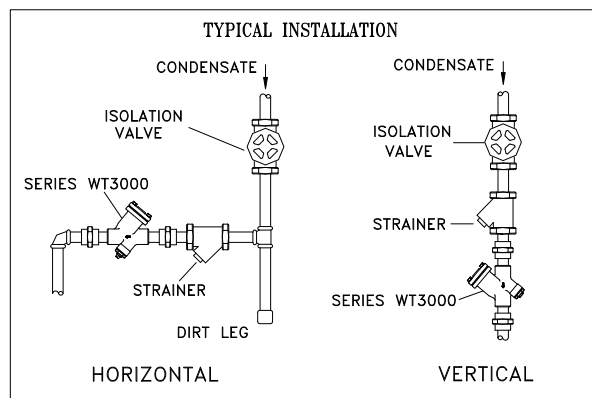

WT3000

PMO 650 PSIG
TMO Sat. Steam Temp.
PMA 906 PSIG @ 100°F
TMA 750°F @ 725 PSIG

WT4000

PMO 300 PSIG
TMO Sat. Steam Temp. bolts
PMA 906 PSIG @ 100°F
TMA 750°F @ 725 PSIG

ACTION

a) Open valve.
b) Check units and clean.

a) Clean trap or replace & install strainer if none exists.

b) Replace thermostat

Each Watson McDaniel Company Product is warranted against defects in material and workmanship for one year from date of shipment. This warranty extends to the first retail purchaser only. All defective material must be returned to the person from whom you purchased the Product, transportation prepaid, free of any liens or encumbrances, and if found to be defective will be repaired free of charge or replaced, at the warrantor's or seller's option. If the material is replaced, any replacement will be invoiced in the usual manner and after inspection of alleged defective material an adjustment will be made for depreciation caused by purchaser's use. In no event will Watson McDaniel Company be liable to do more than refund the original contract price. Incidental and consequential damages are excluded, whether under this warranty or otherwise. All implied warranties, including warranties of merchantability and fitness for a particular purpose, are disclaimed and excluded.